

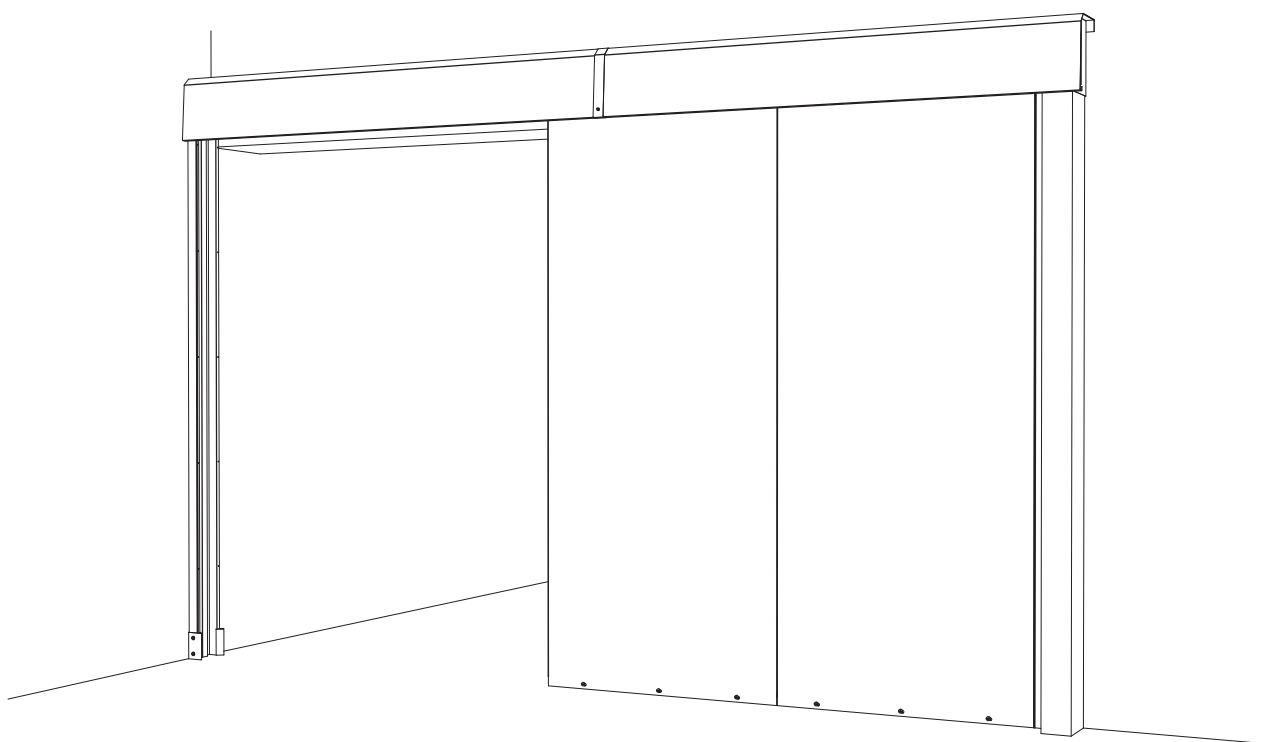

NOVOSLIDE 1 ANTA INCONTRO PIANO



INSTALLATION AND MAINTENANCE

Installazione e manutenzione

Installation et maintenance

Instalación y mantenimiento

Installation und Wartung

Kurulum ve bakım

Монтаж и техническое обслуживание

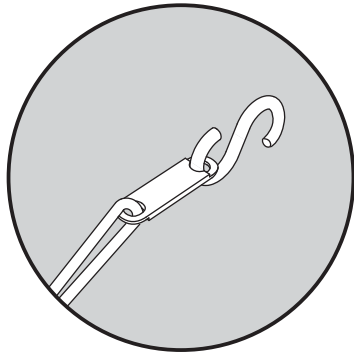

Closing with fuse

Chiusura con fusibile
Avec fusible thermique
Con fusible térmico
Mit Thermosicherung
Termal sigorta ile

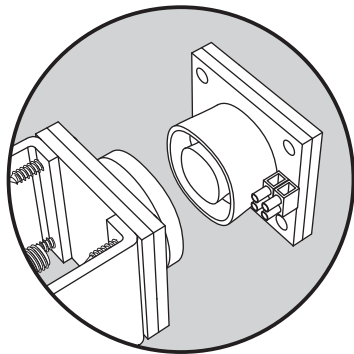

Closing with electromagnet

Chiusura con elettromagnete
Fermeture par électroaimant
Cierre con electroimán
Schließen mit Elektromagnet
Elektromiknatis ile Kapanis

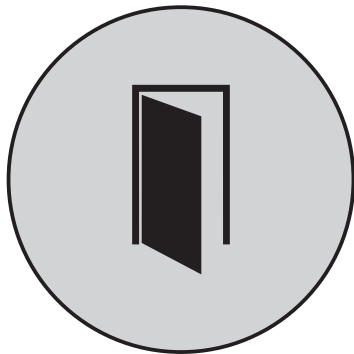

With pass door

Con porta pedonale
Avec porte piétonne
Con puerta peatonal
Mit Gehür
Yaya kapi ile



DOWNLOAD:

<https://www.novoferm.it/download/istruzioni-di-posa/>

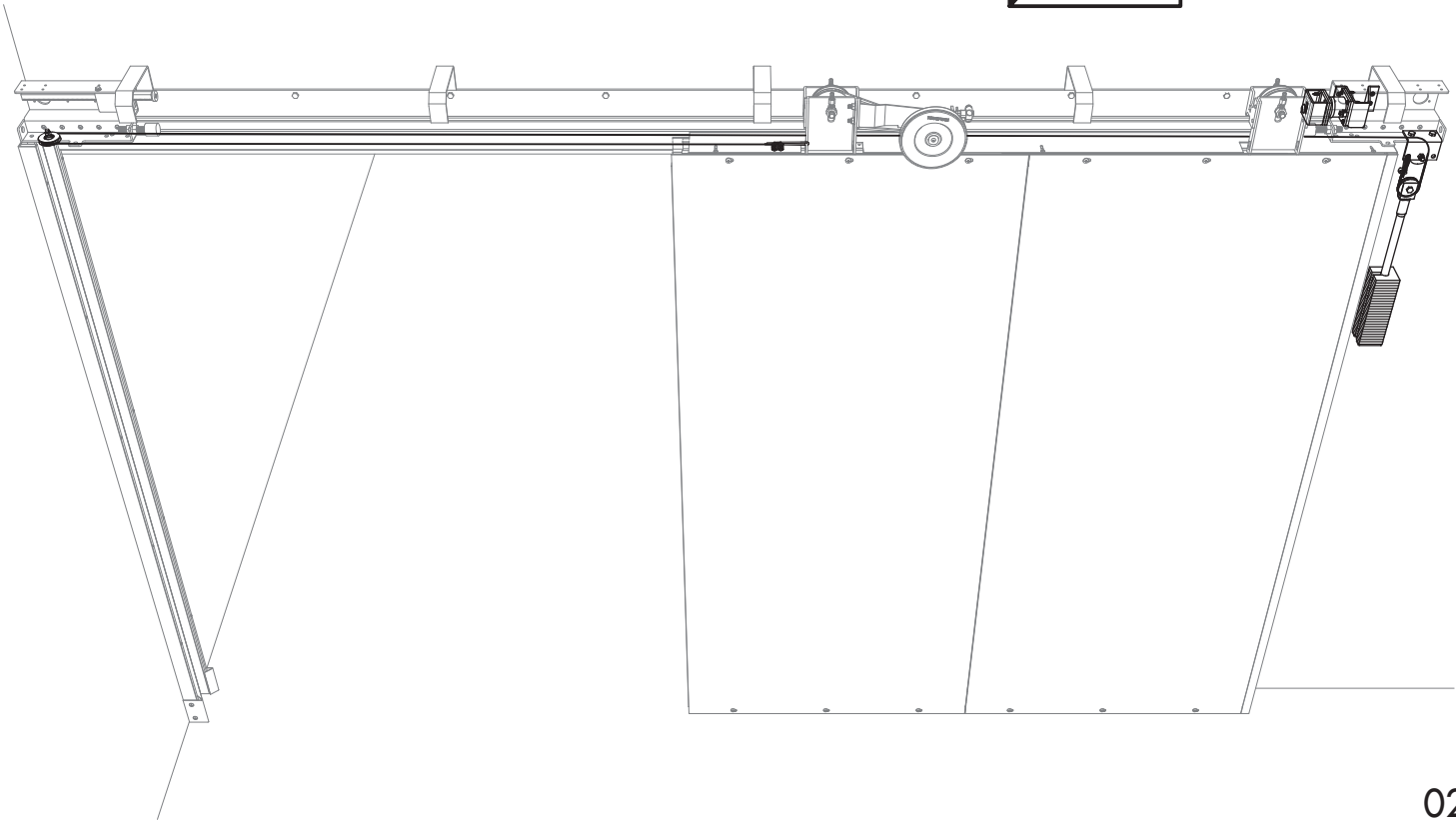
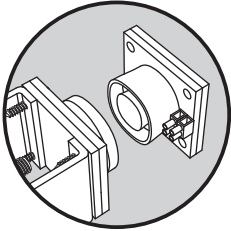
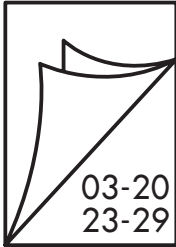
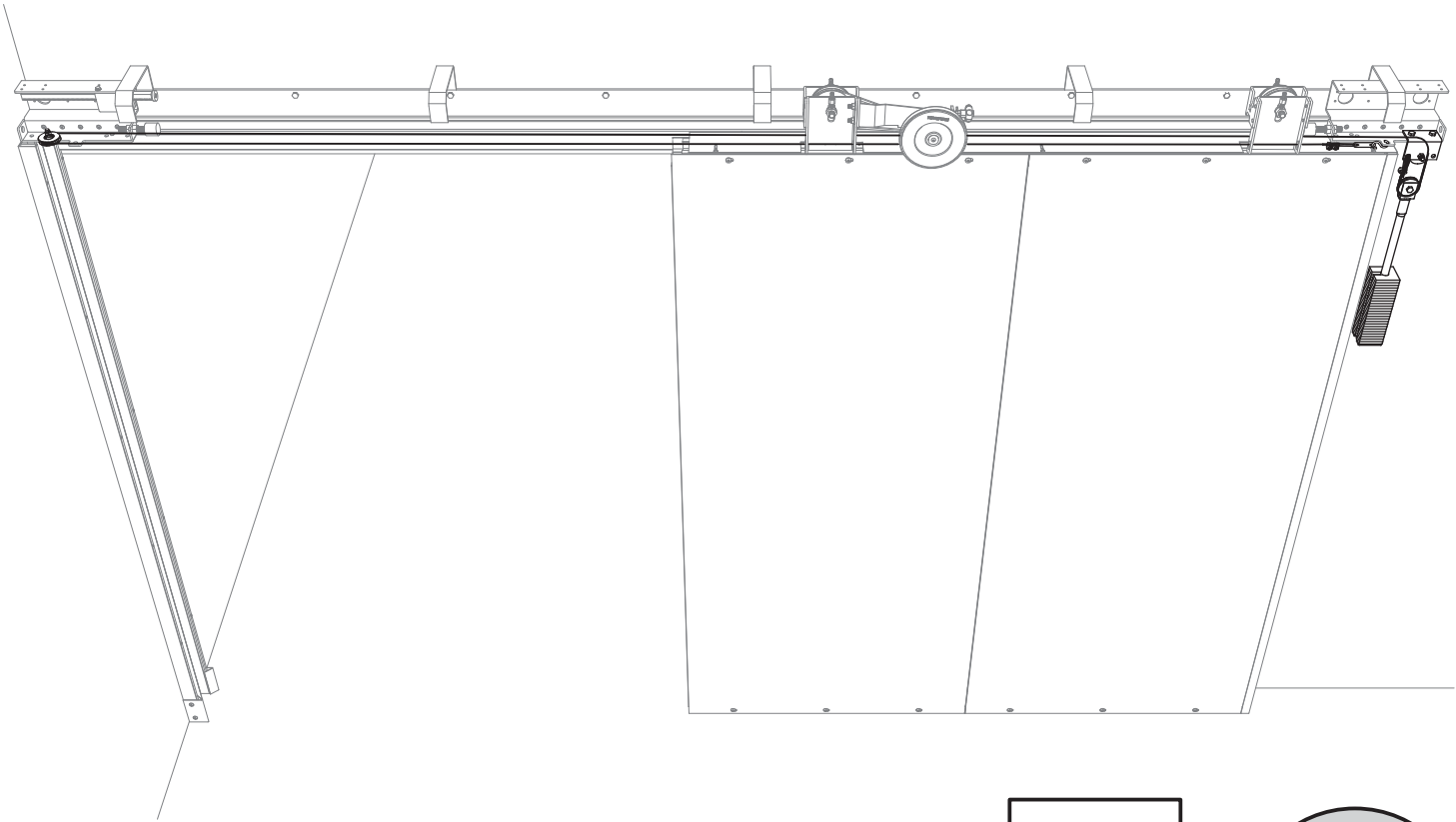
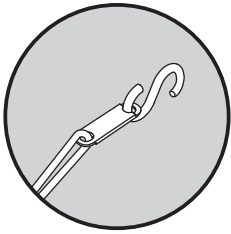
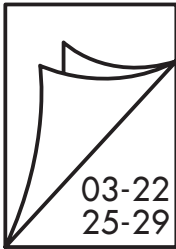

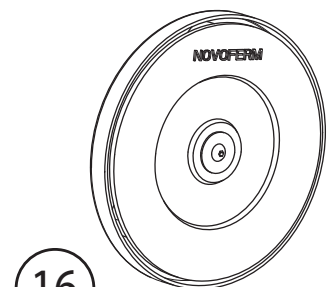
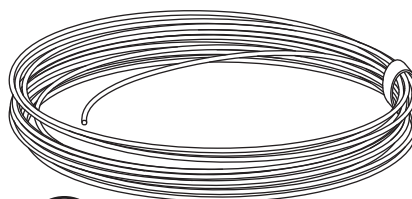
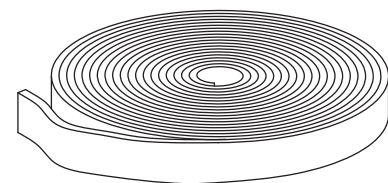
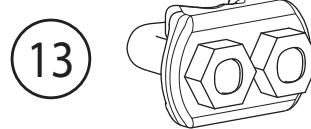
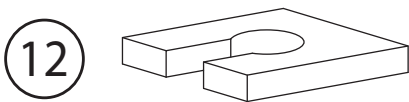
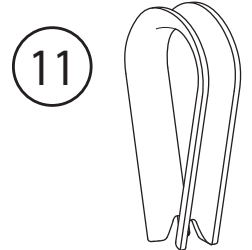
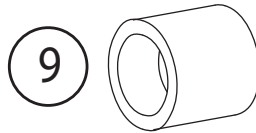
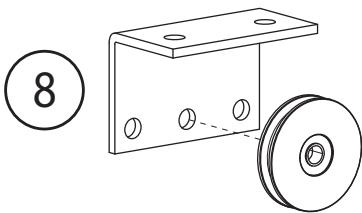
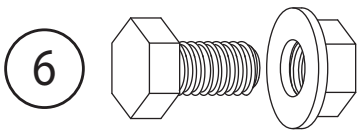
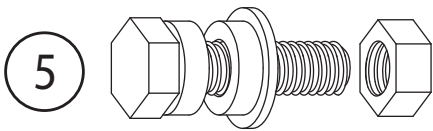
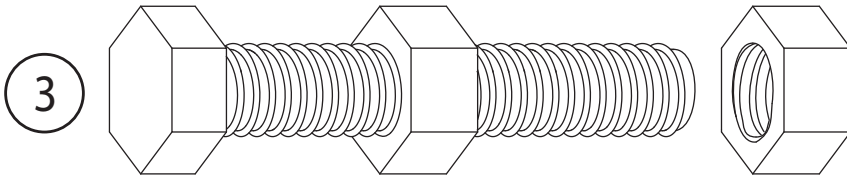
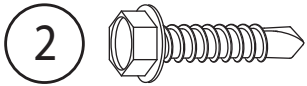
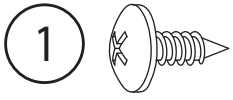

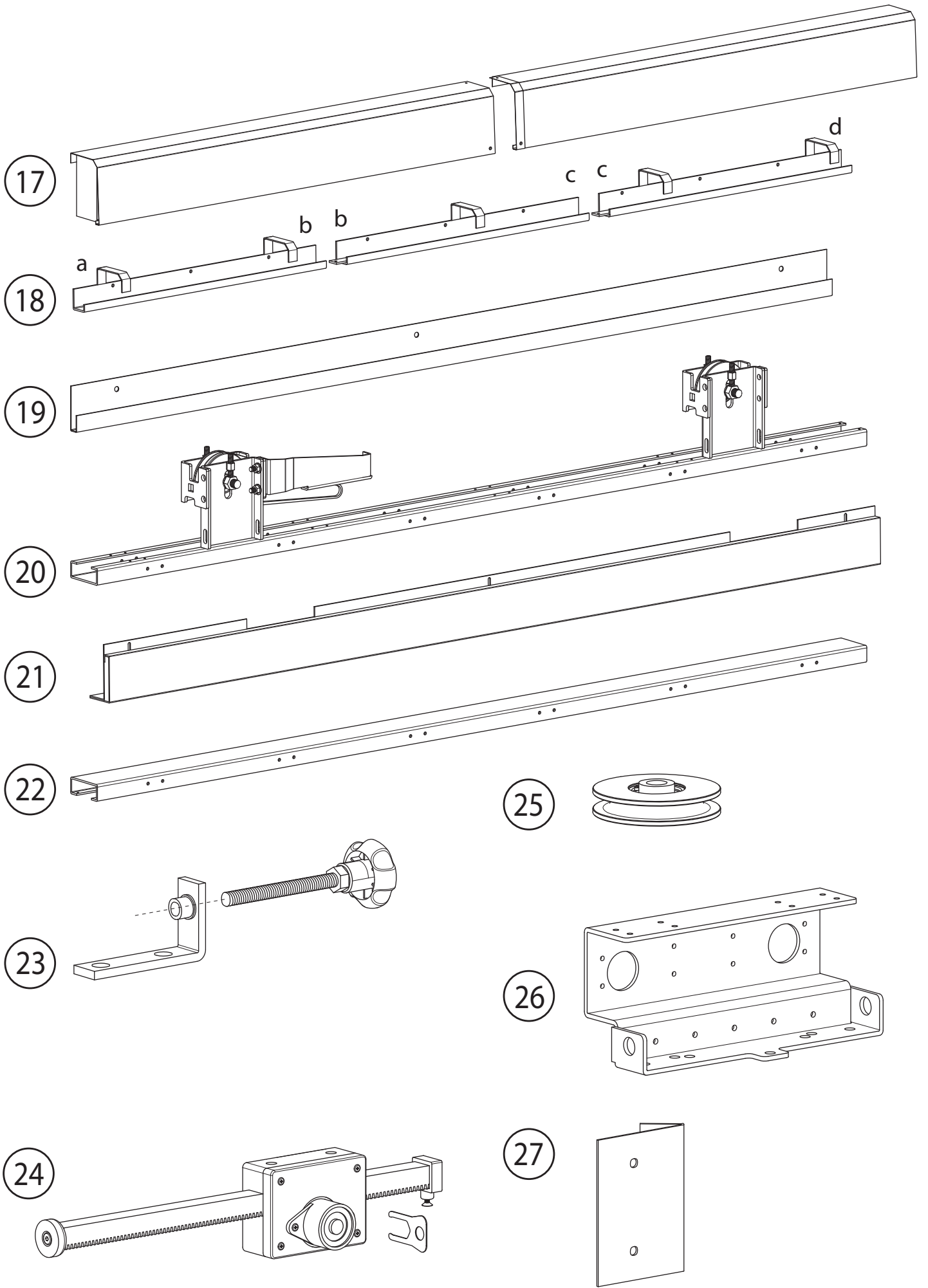

28

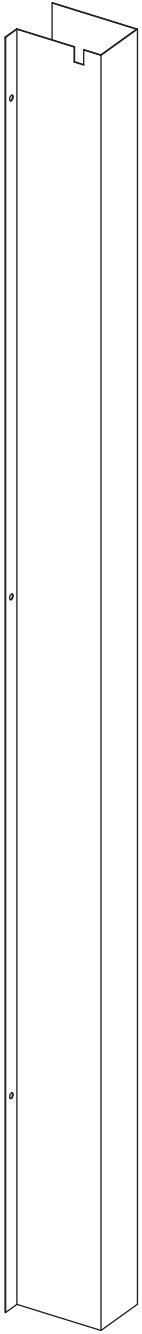

29

30

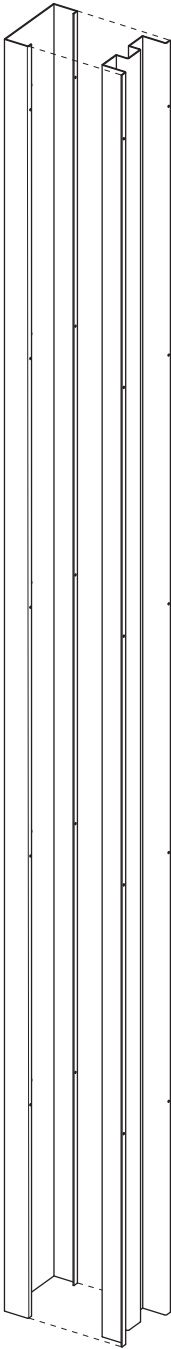

31

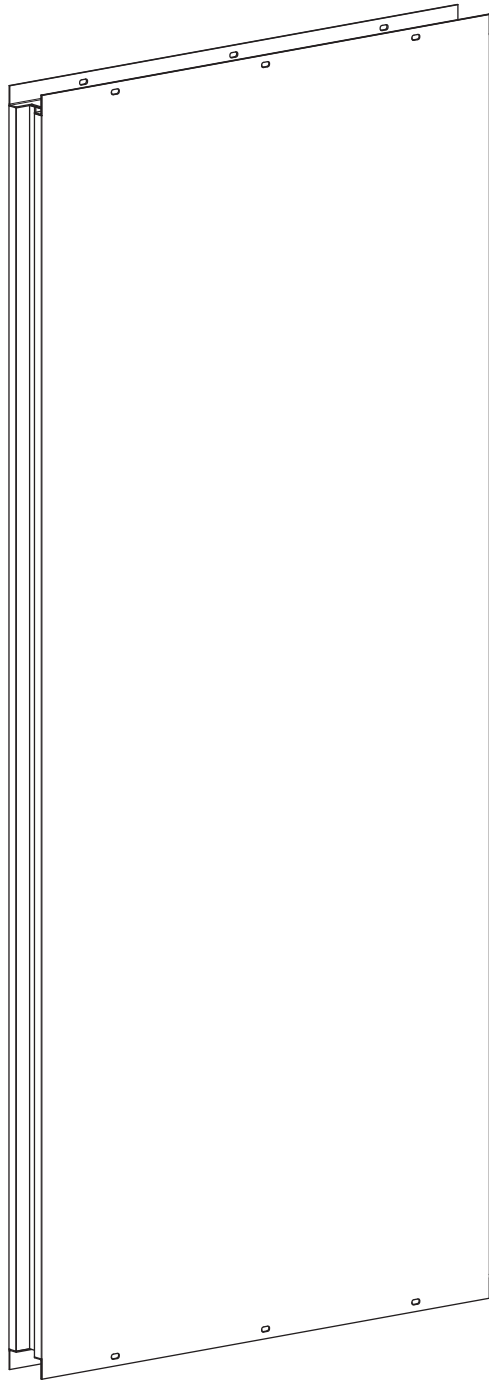

32

33

34

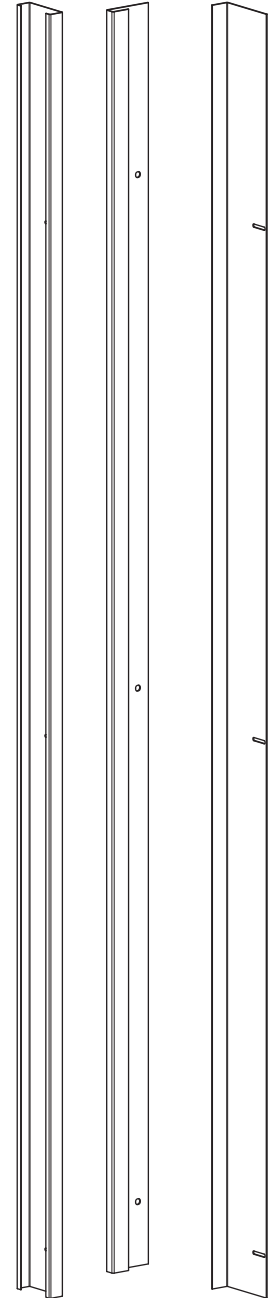

35

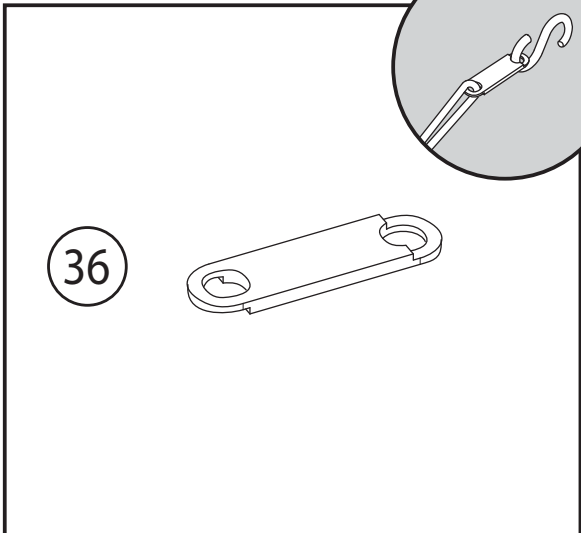
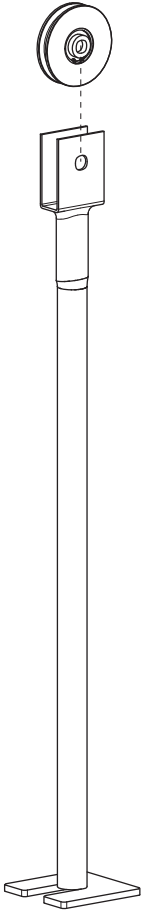

36

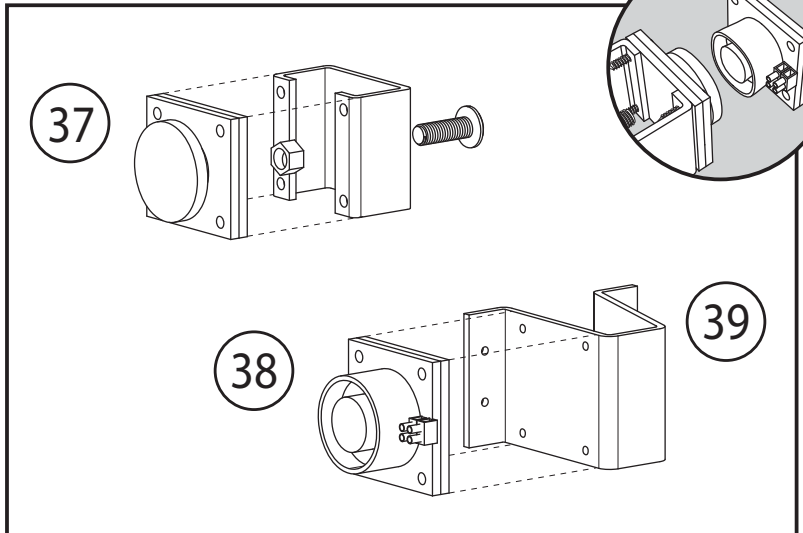
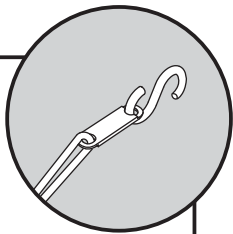

37

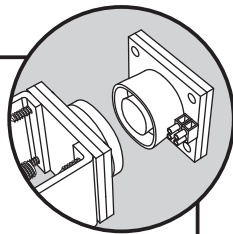

38

39

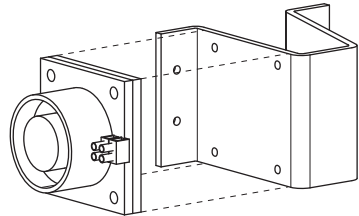

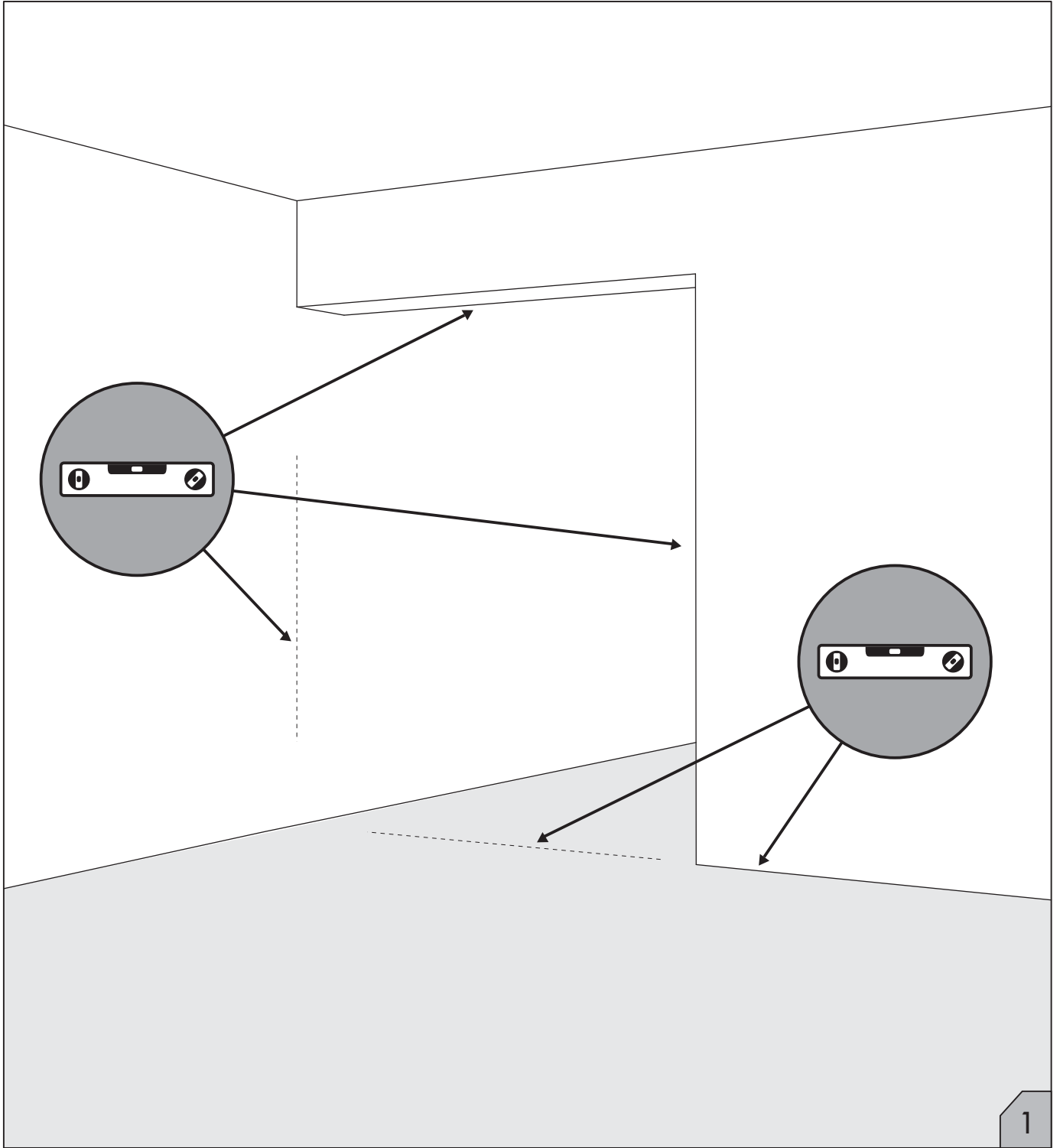

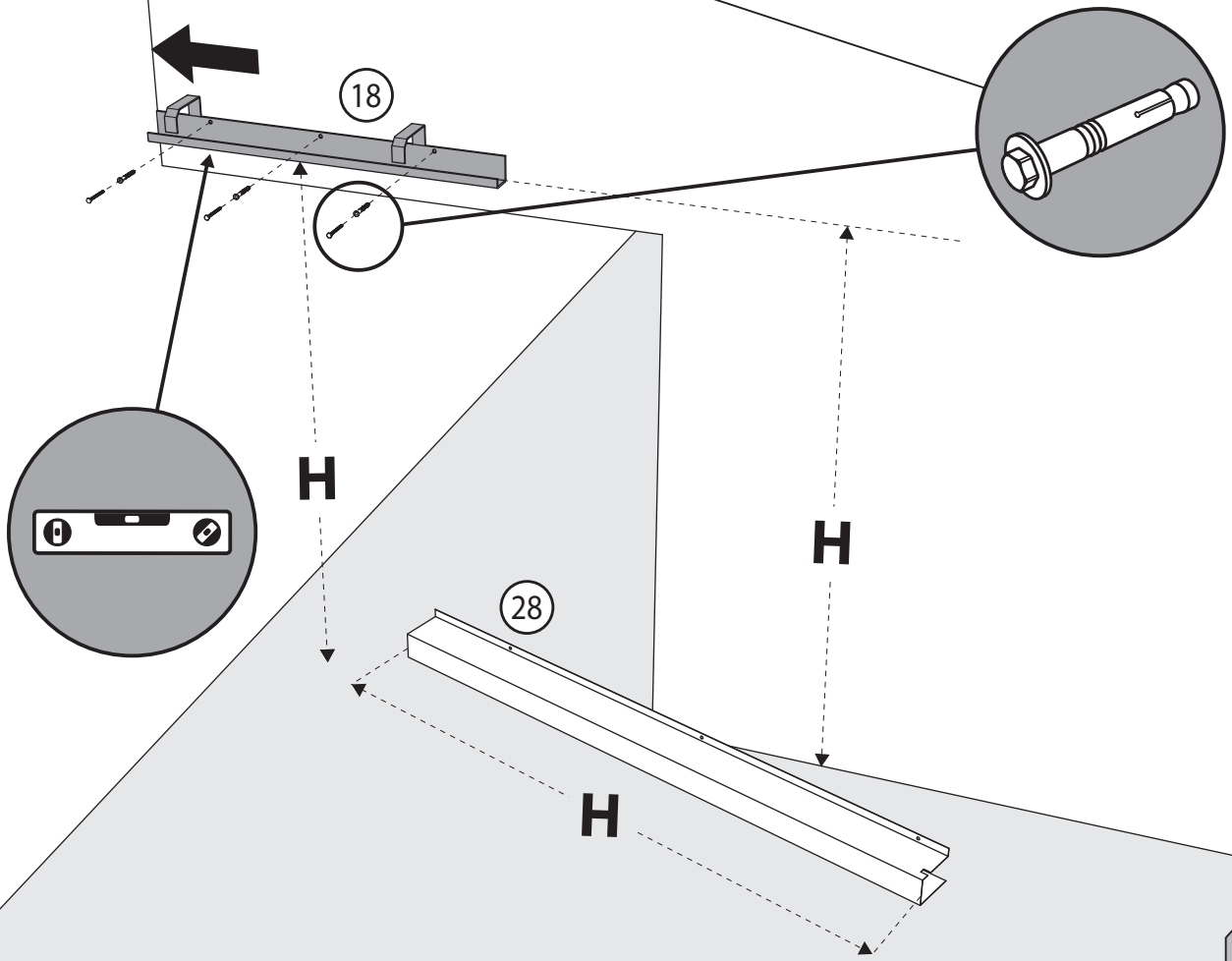
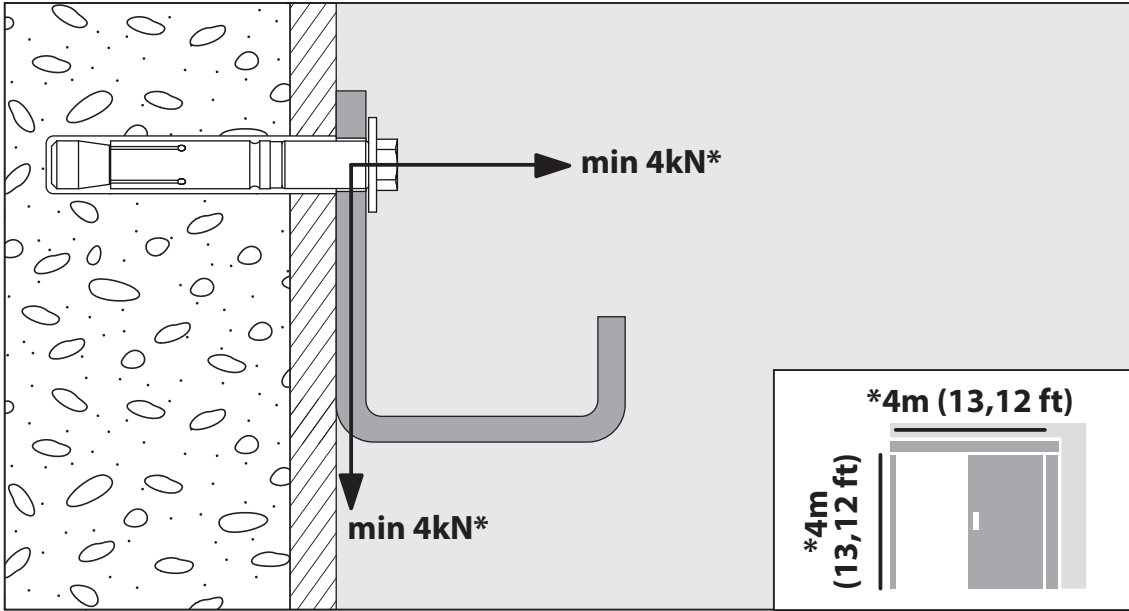
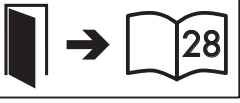
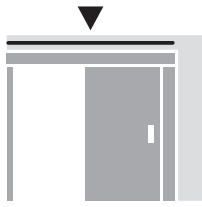

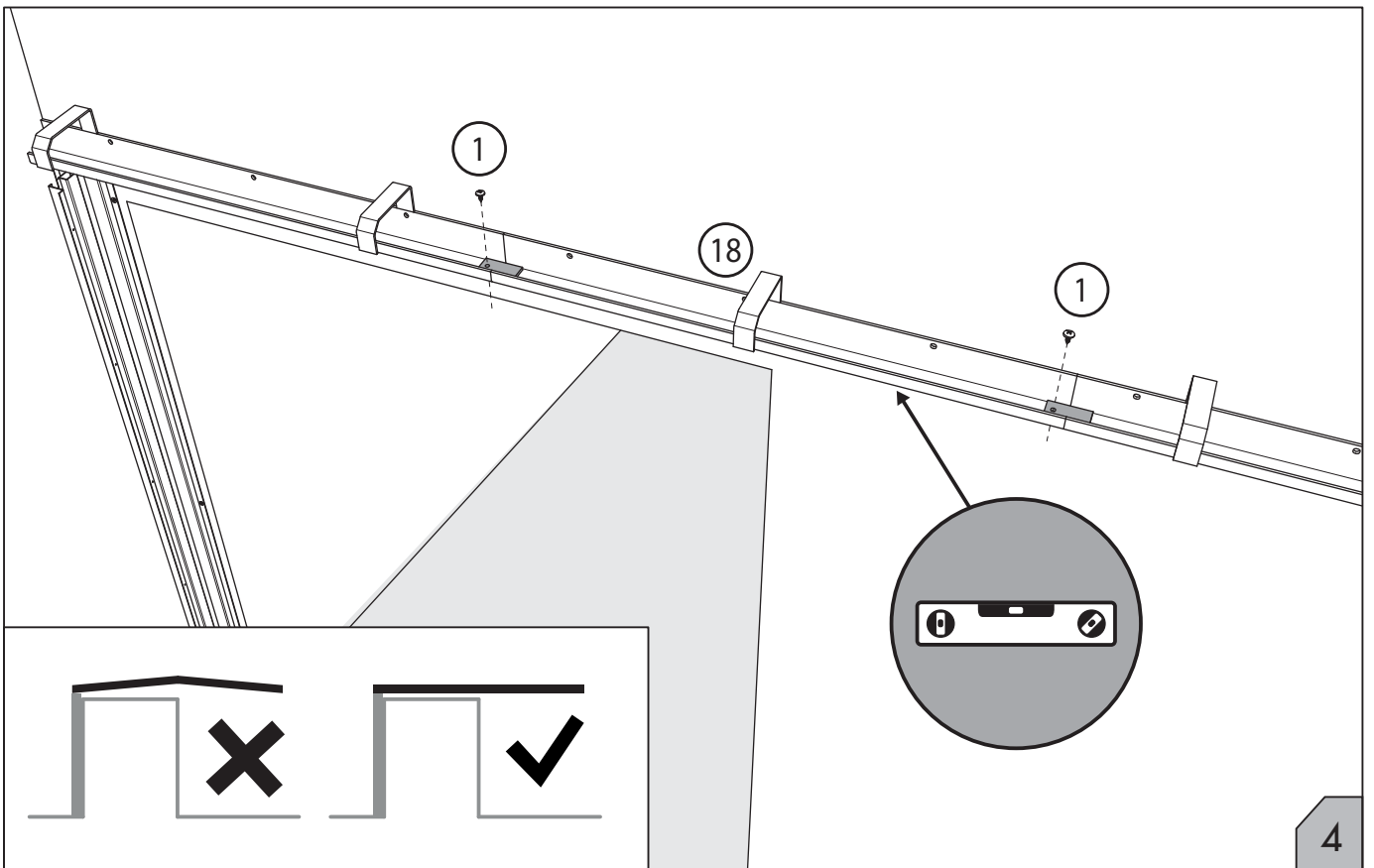
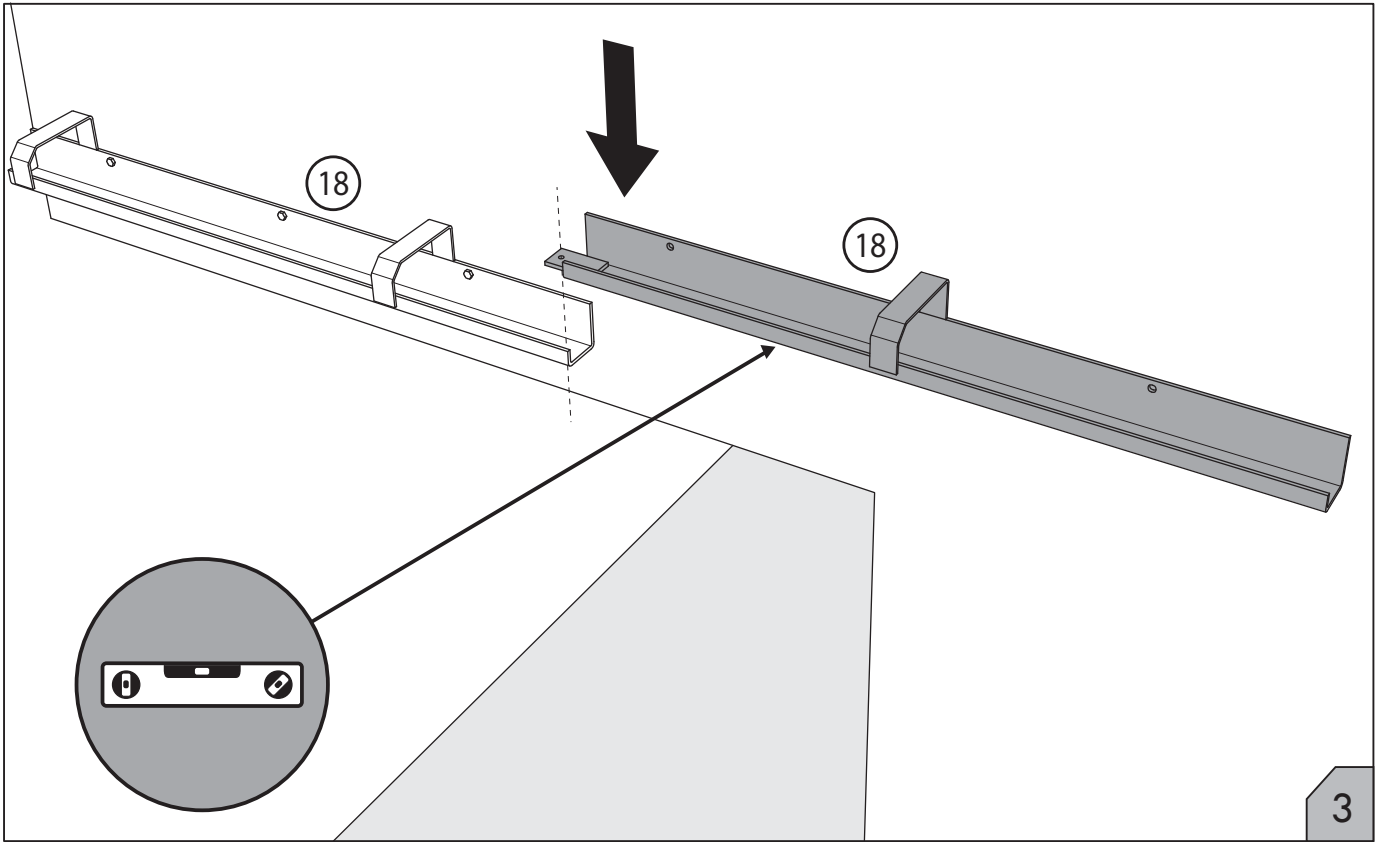
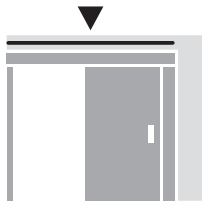

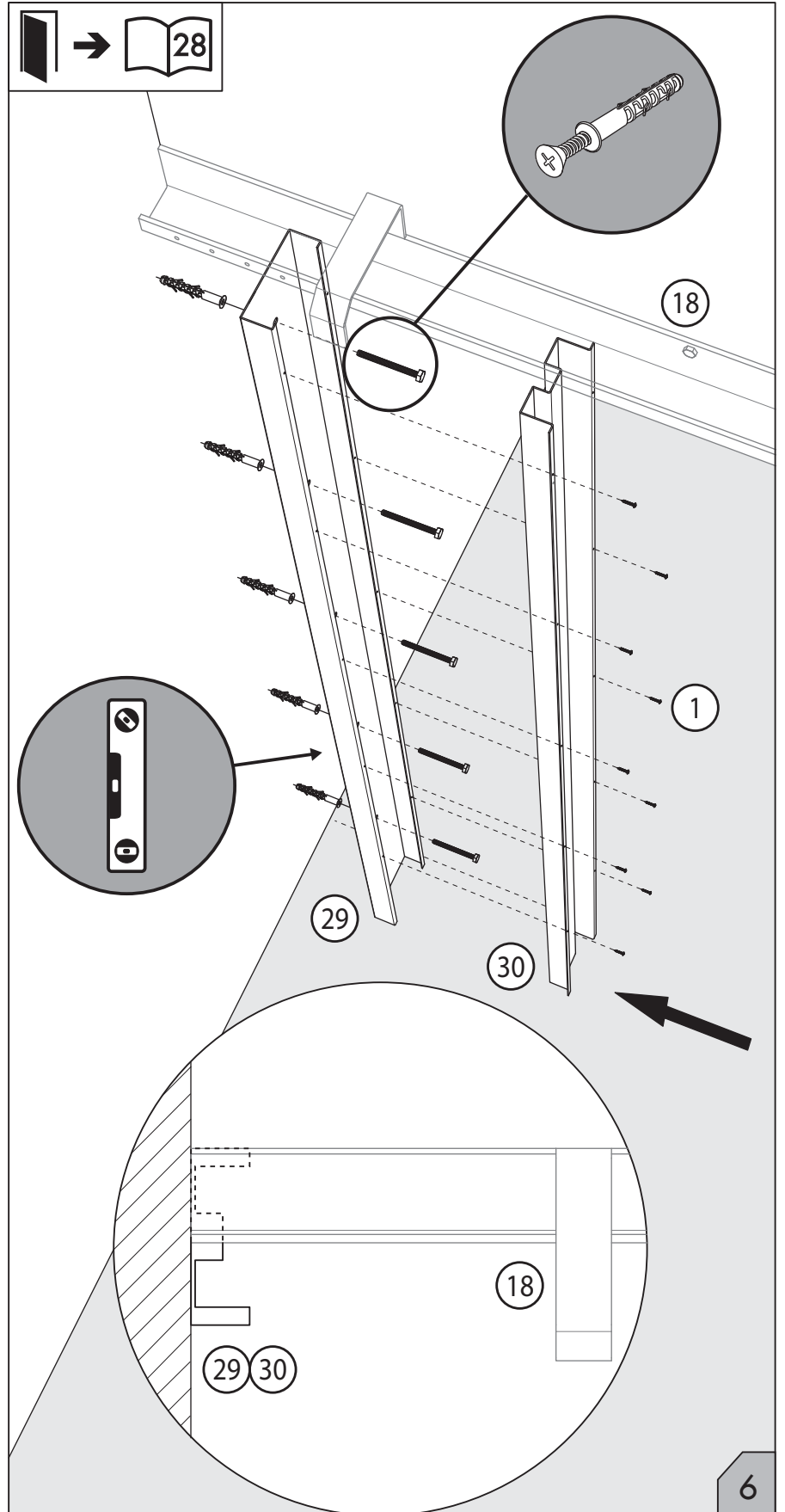
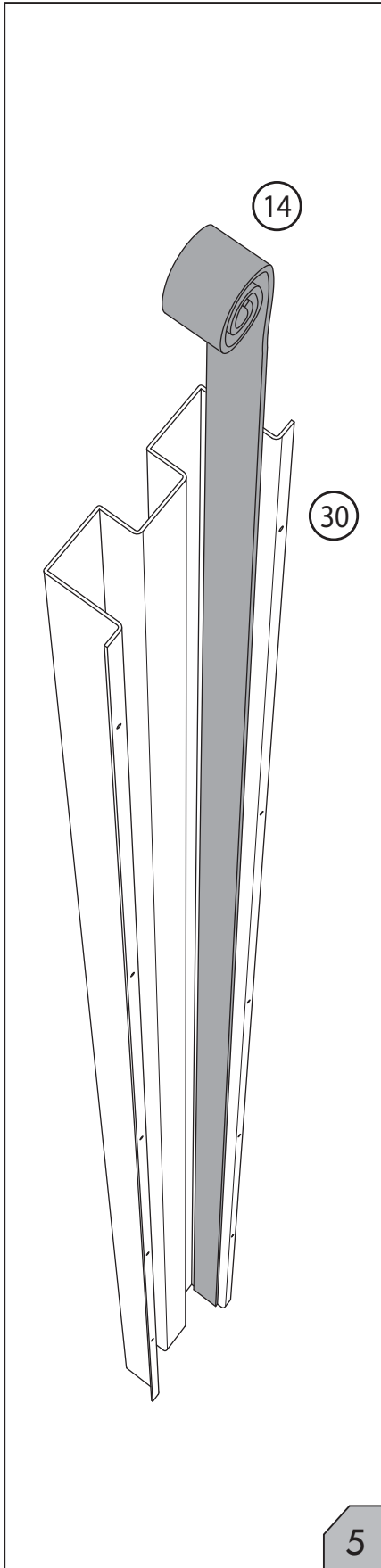
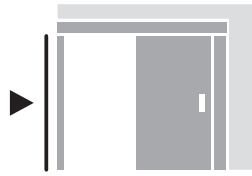

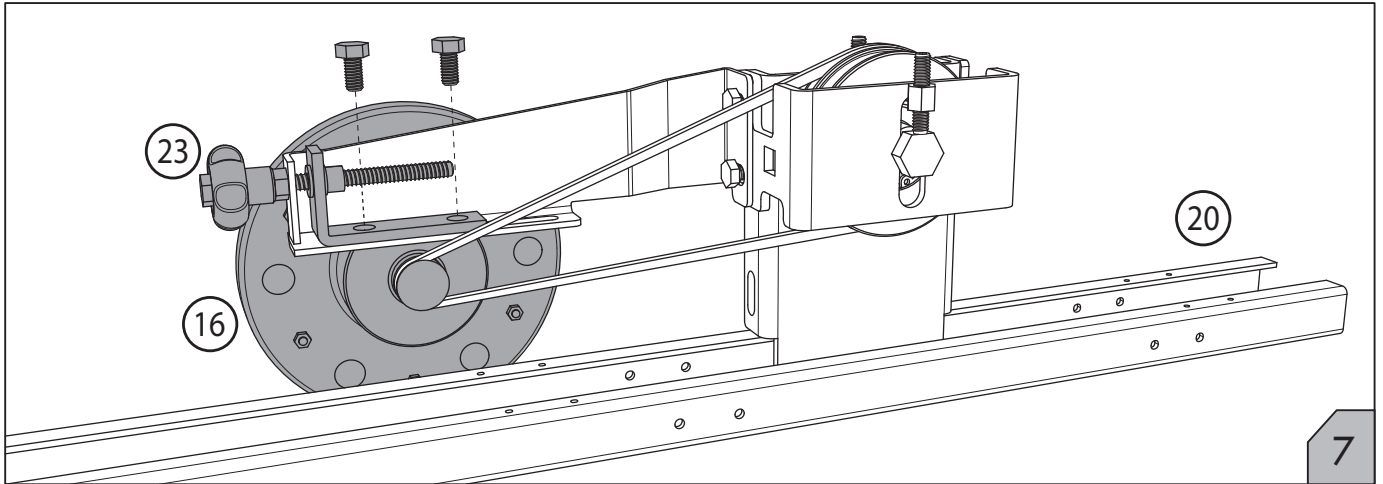
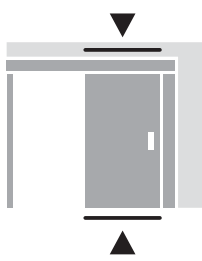

7

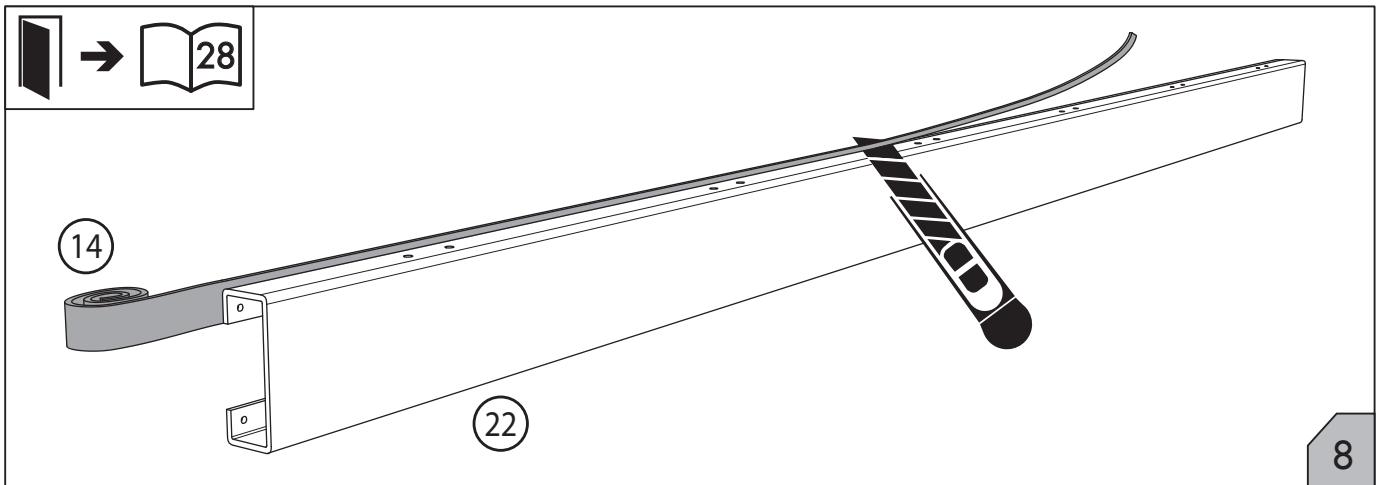

8

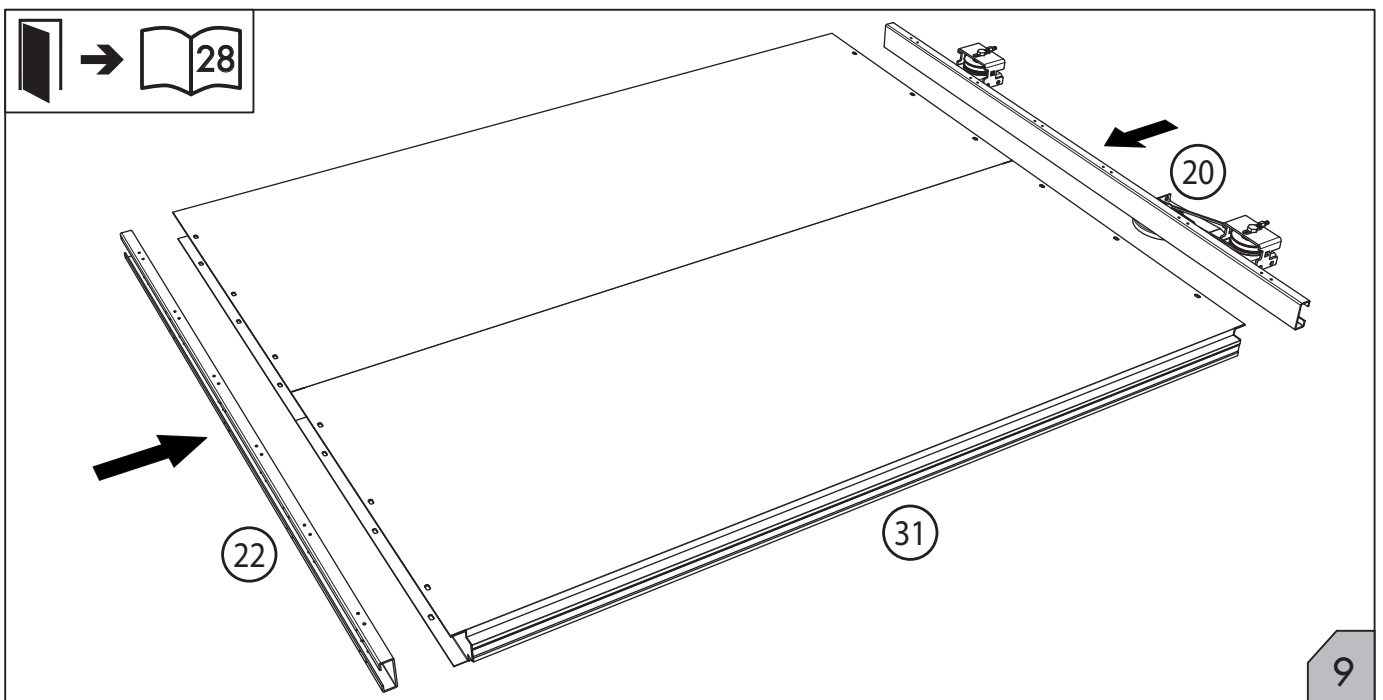

9

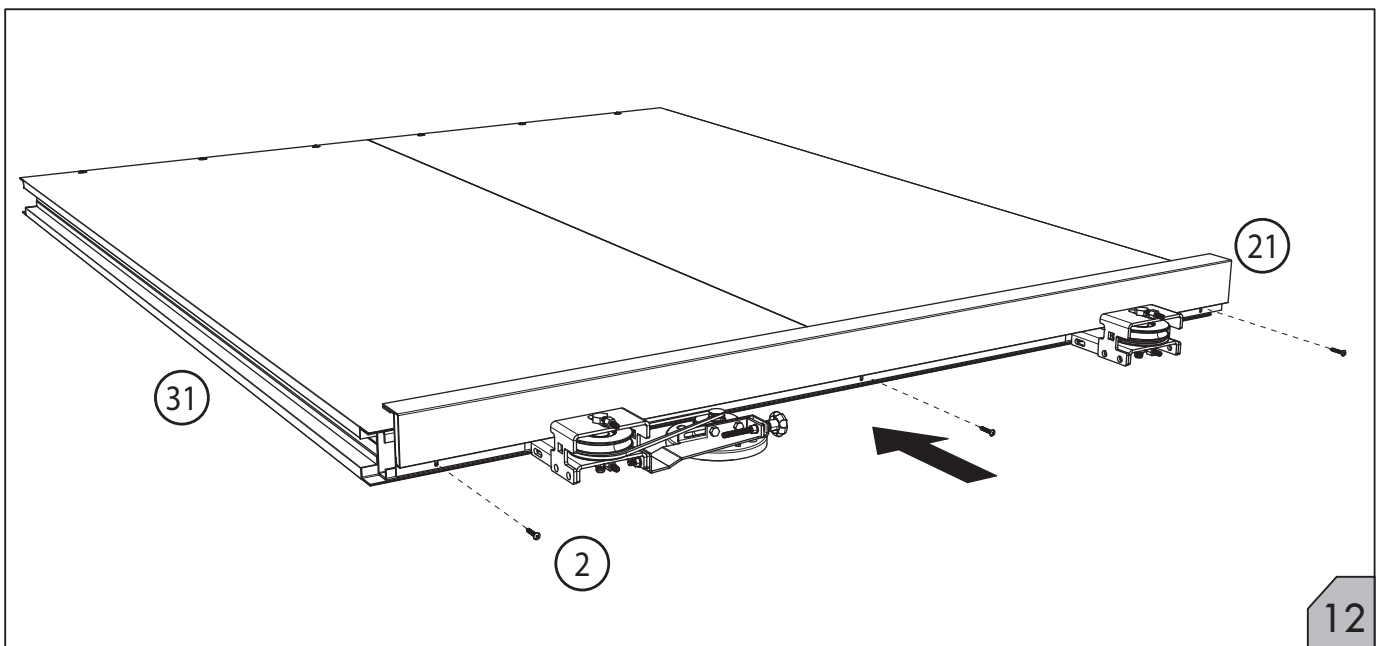
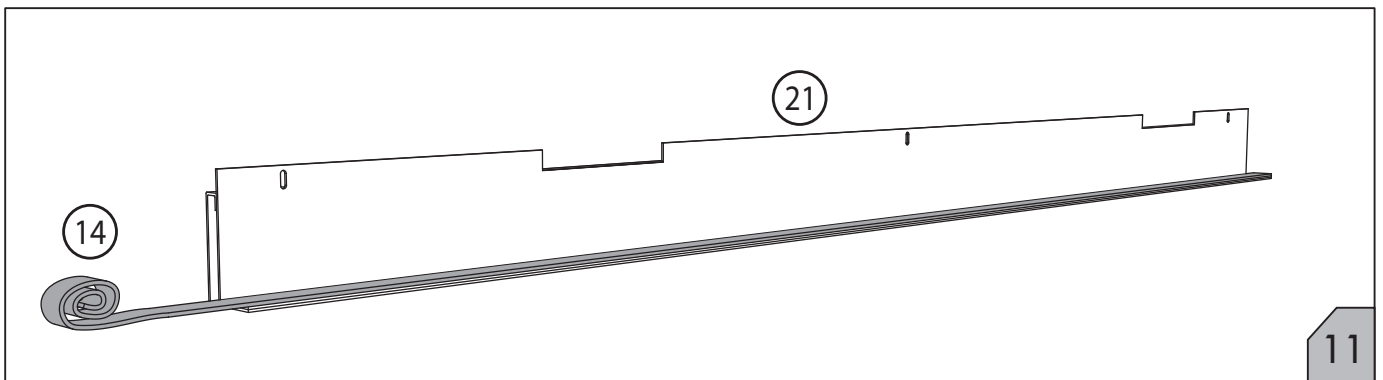
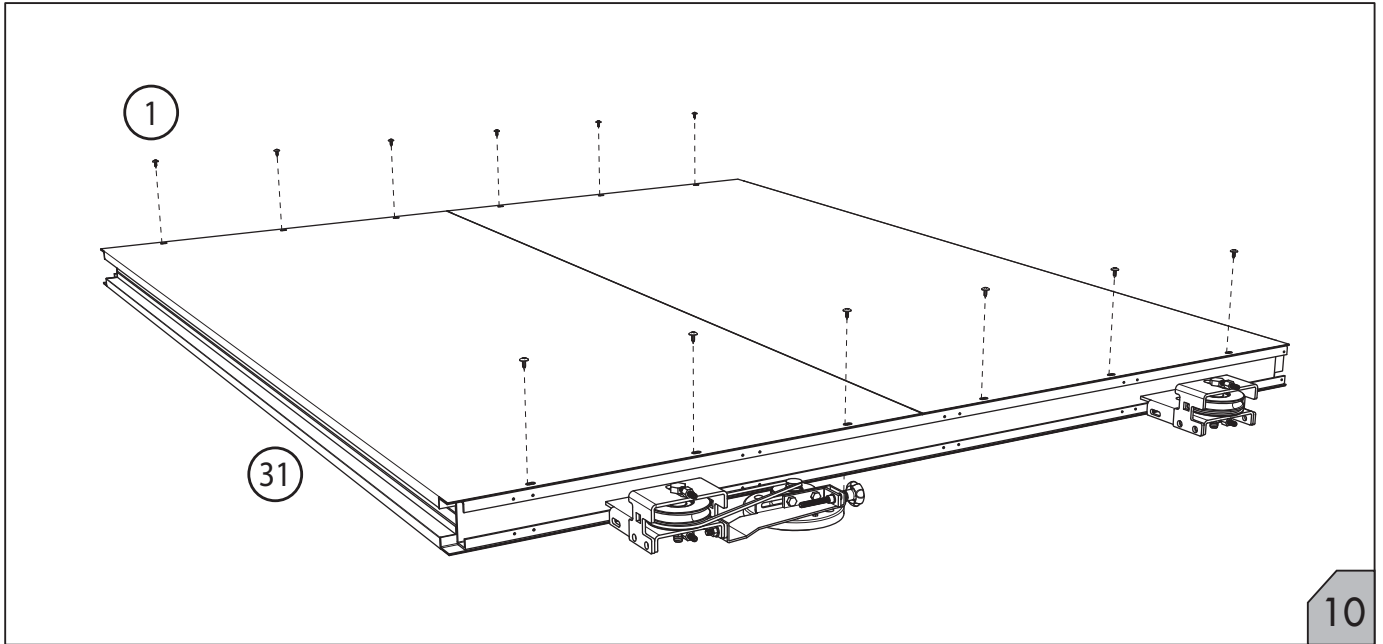
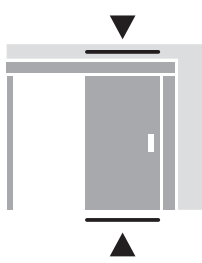

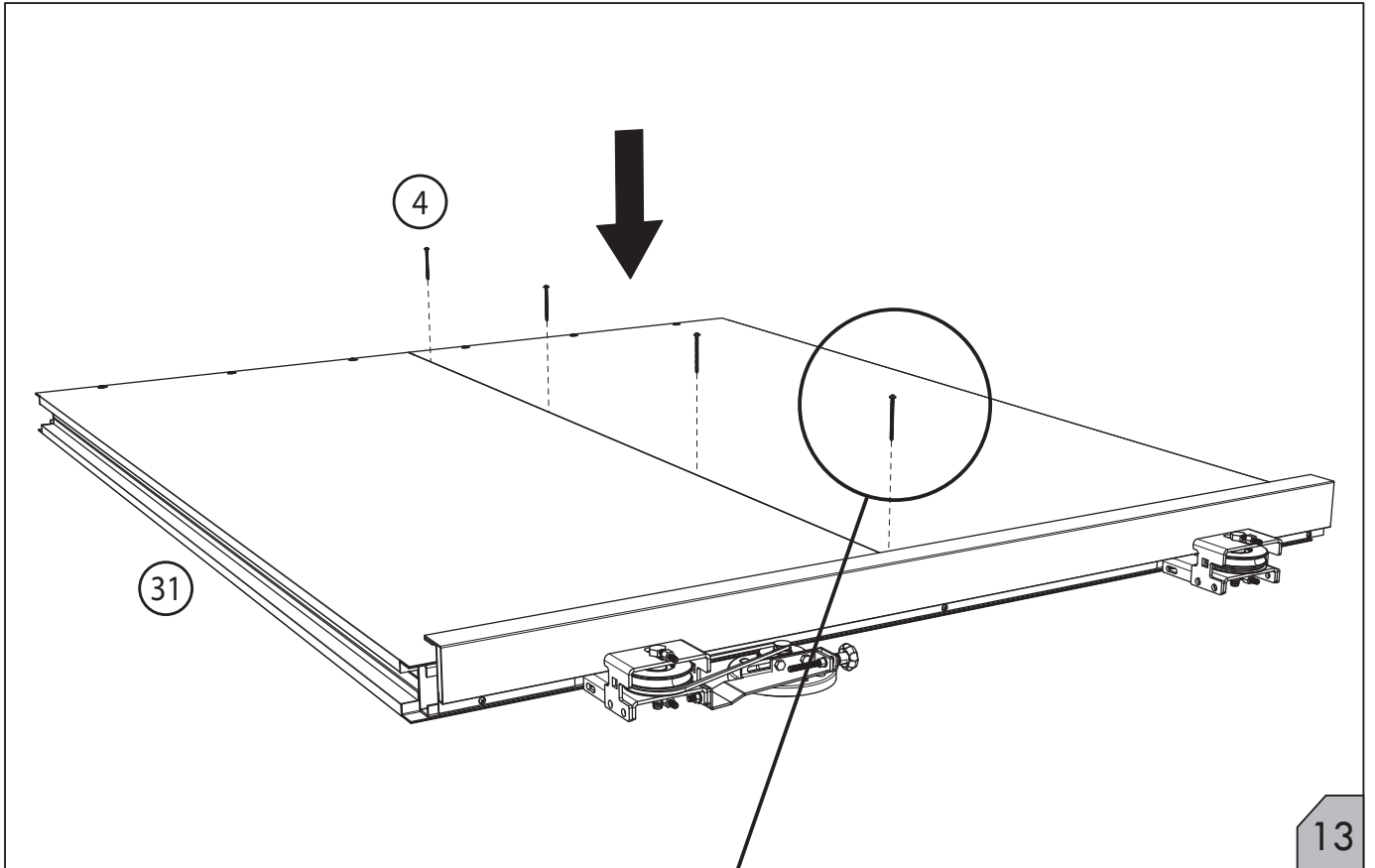
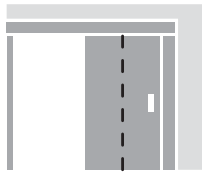

13

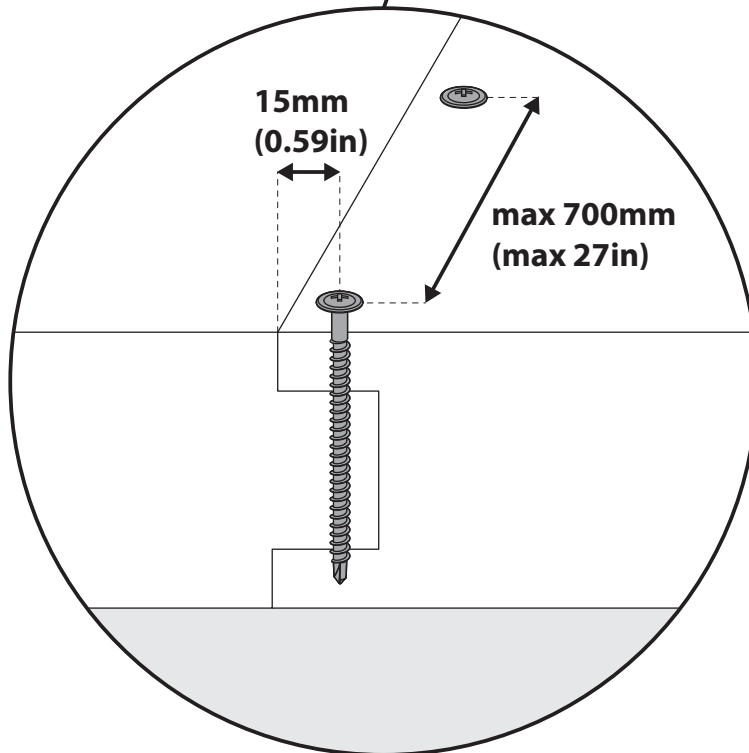

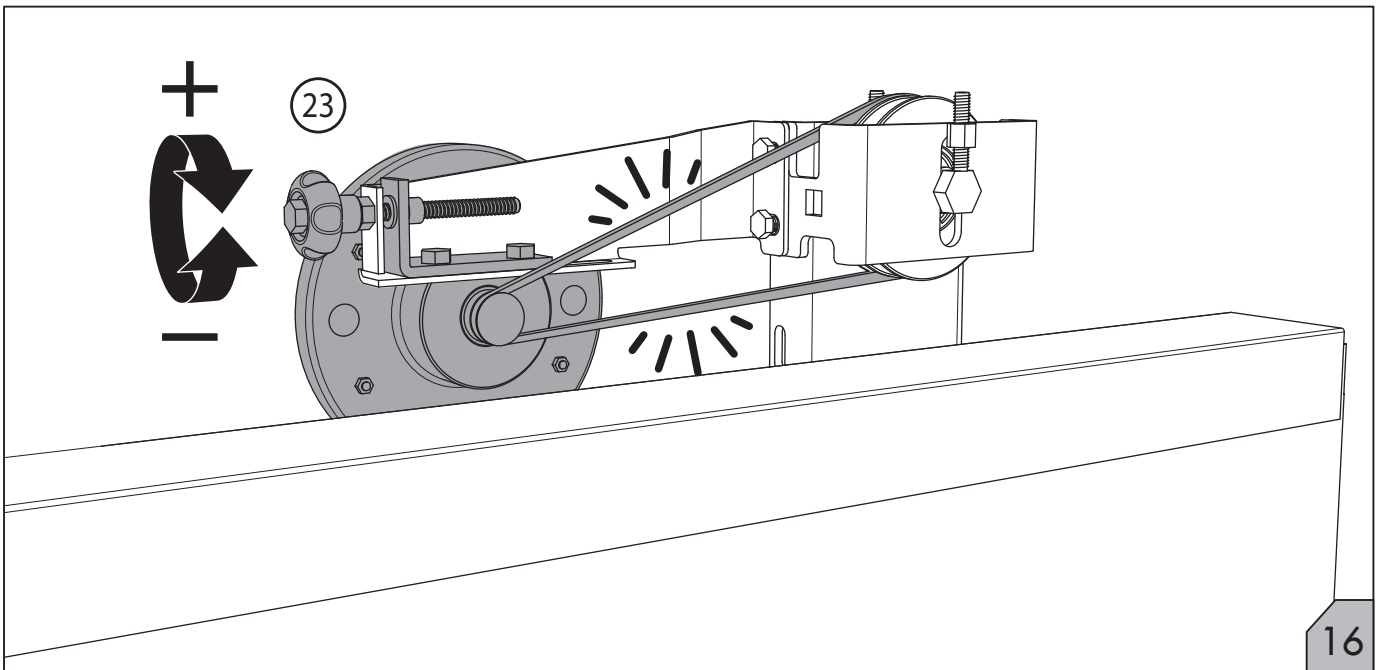
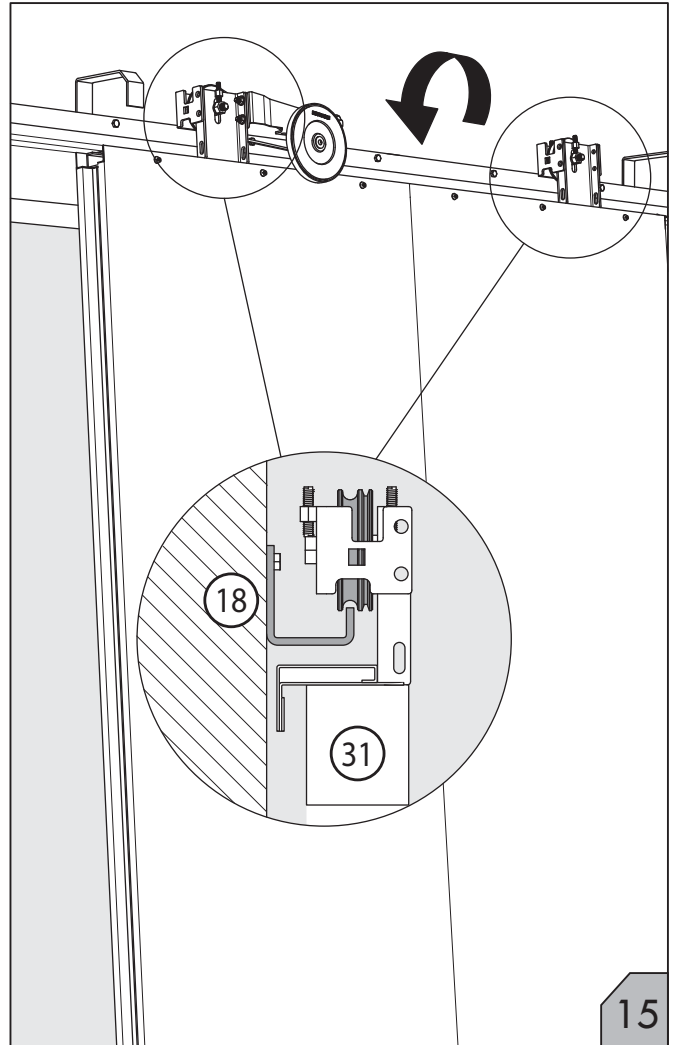
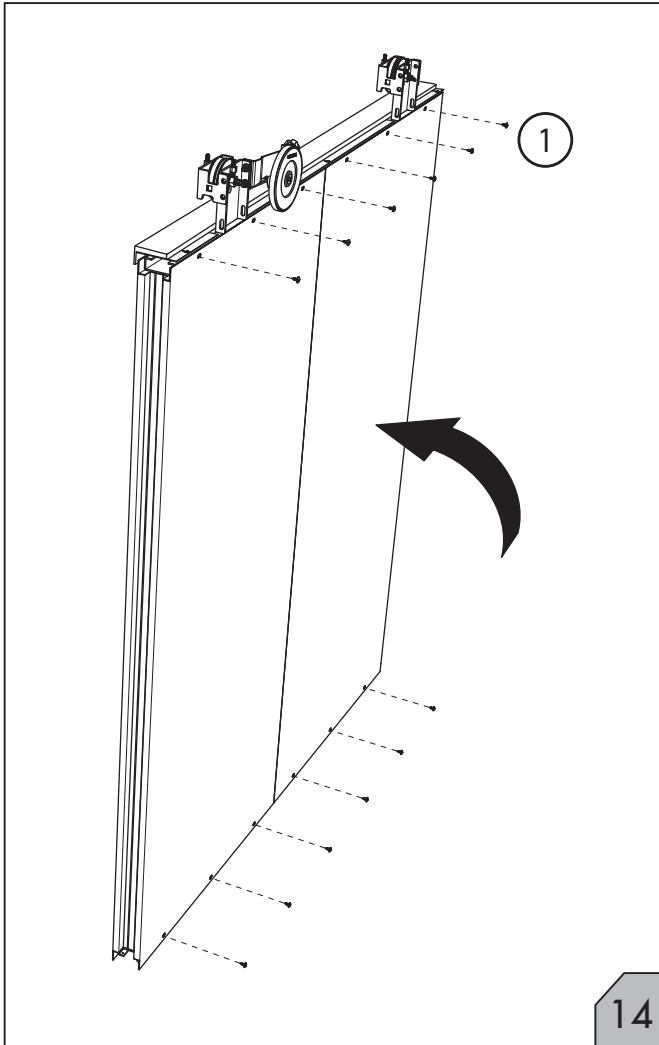
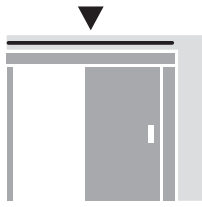

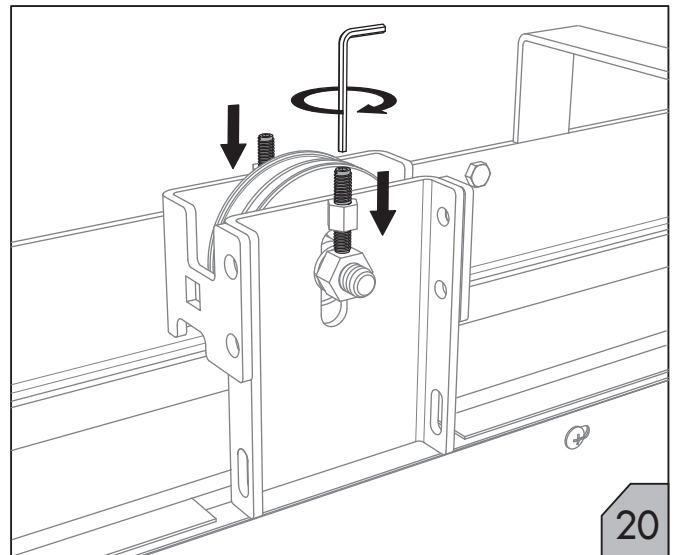
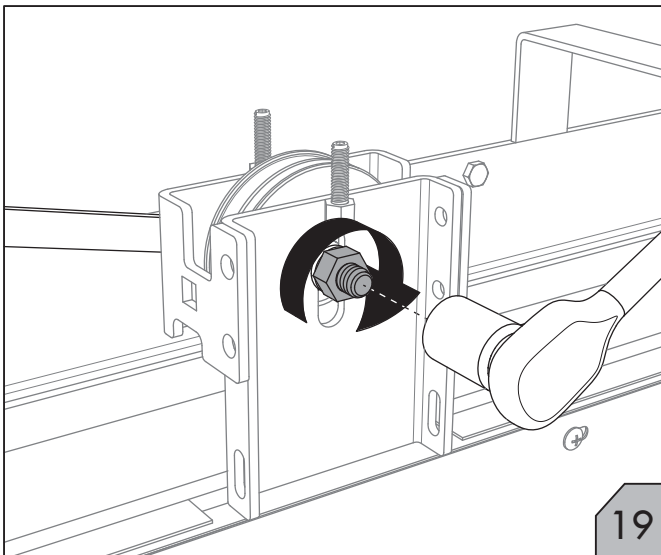
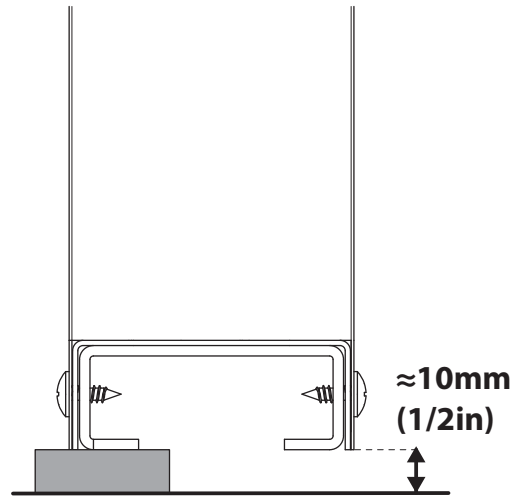
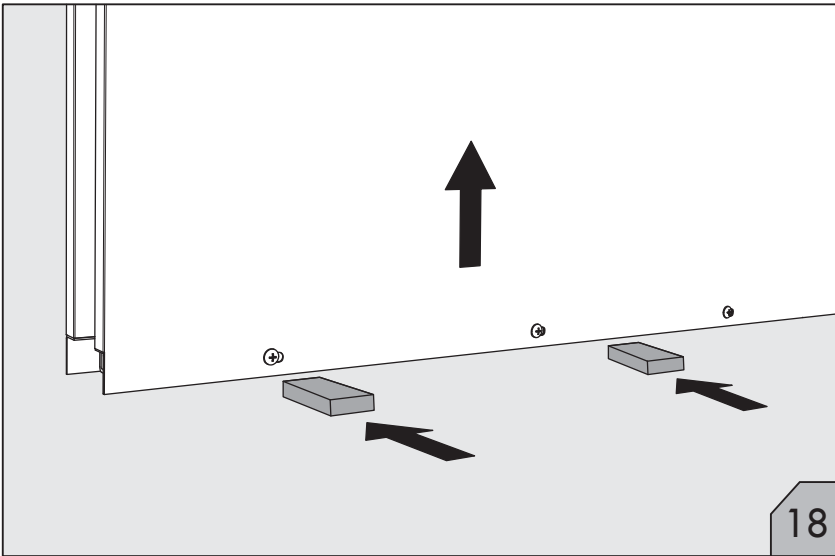
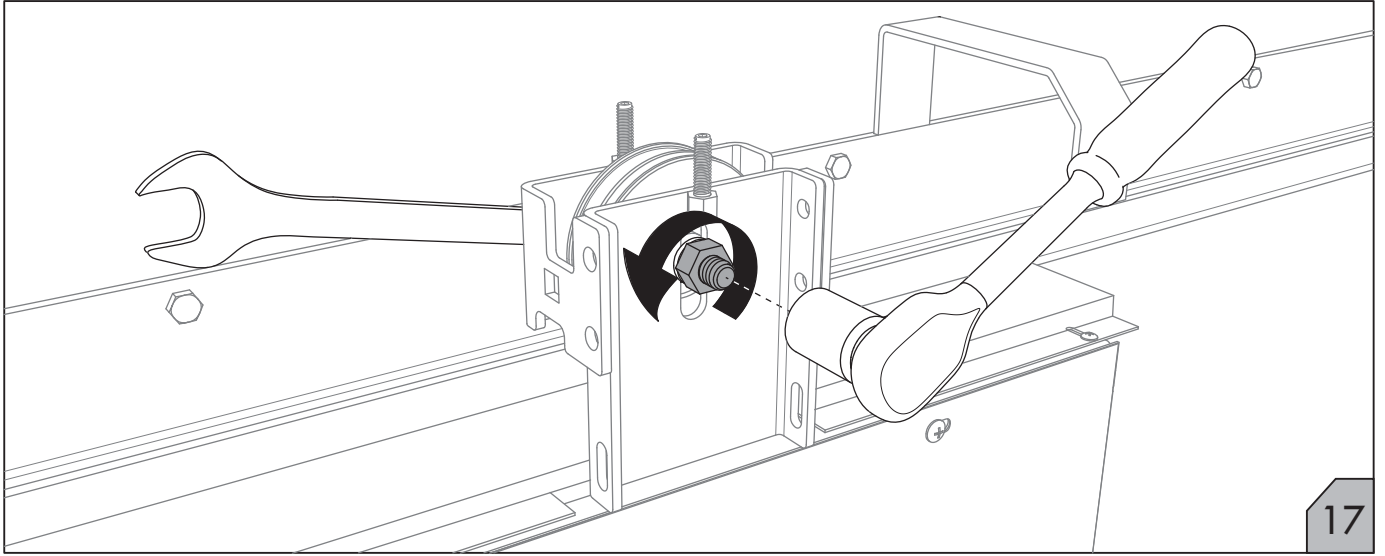
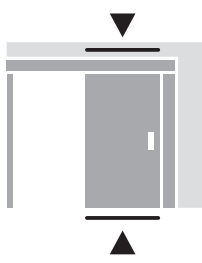

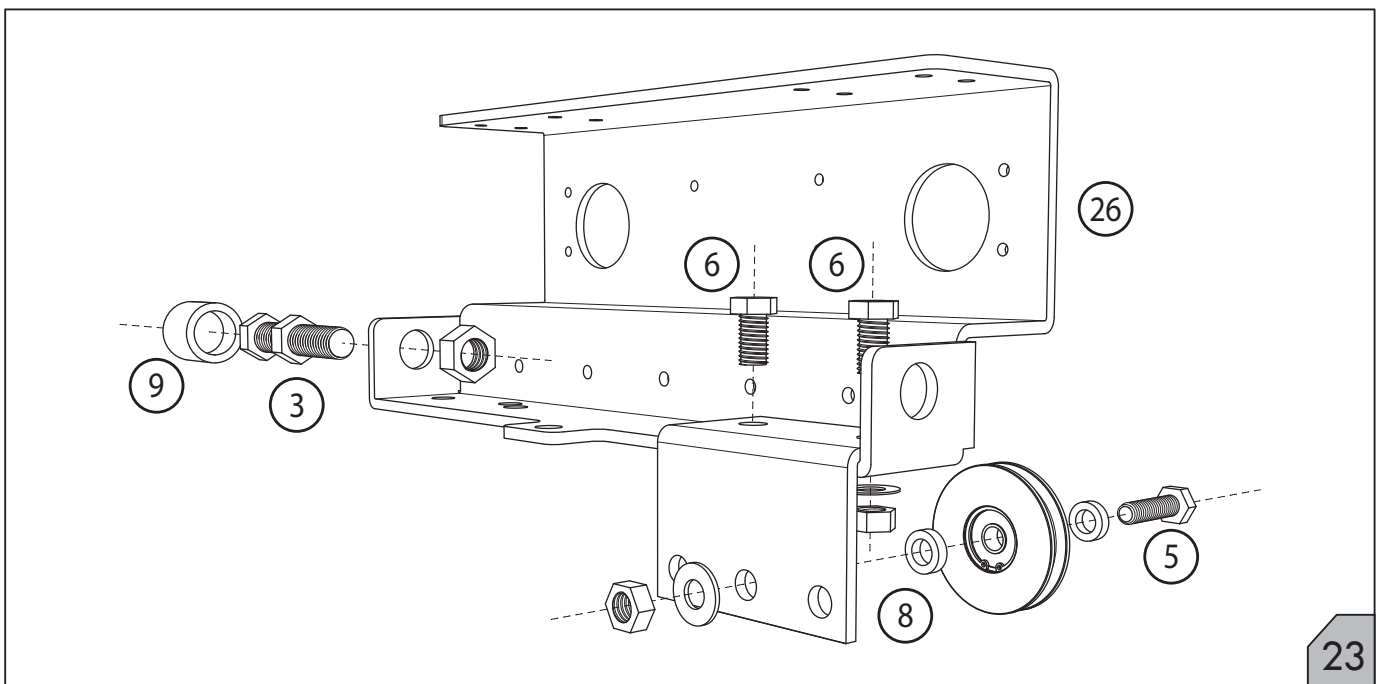
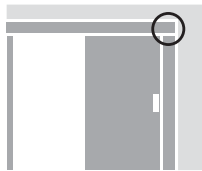
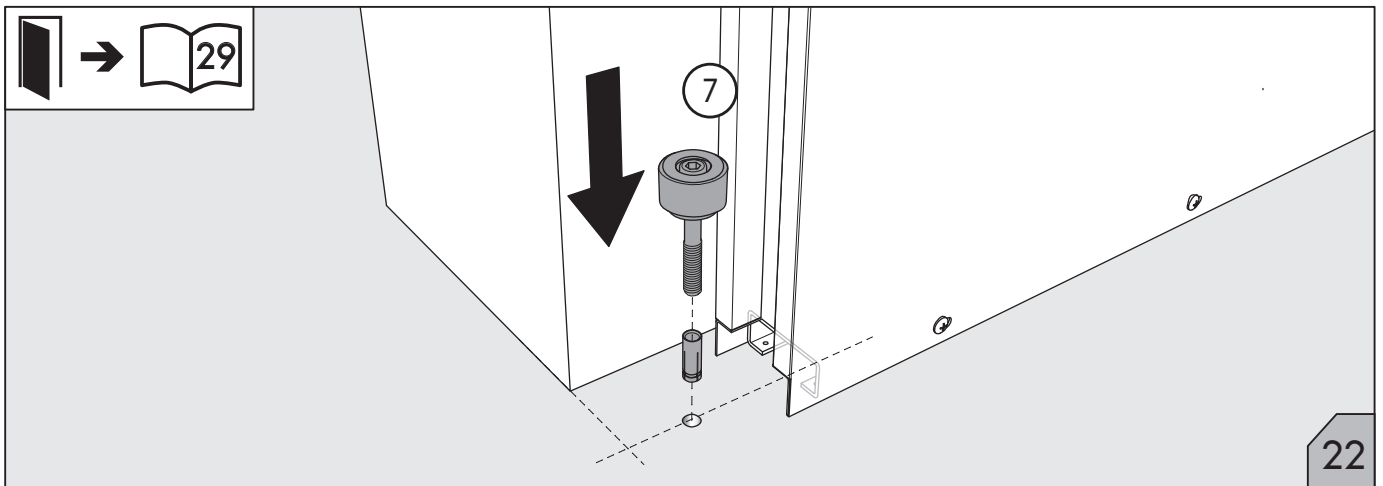
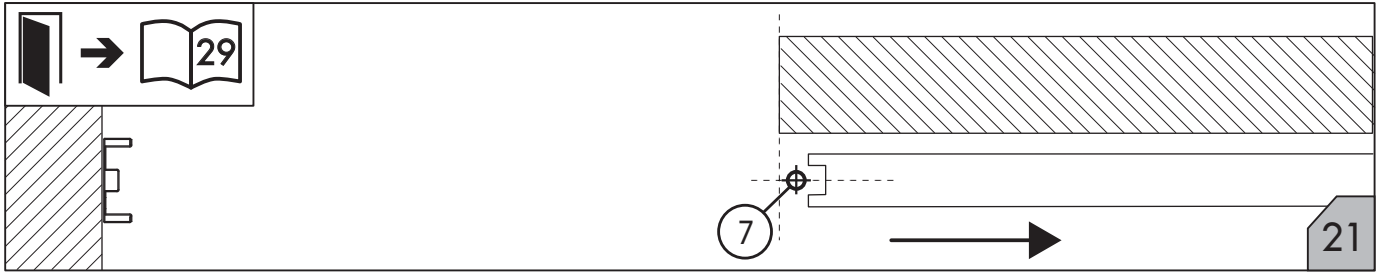
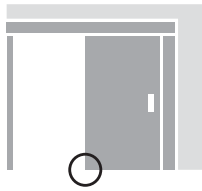

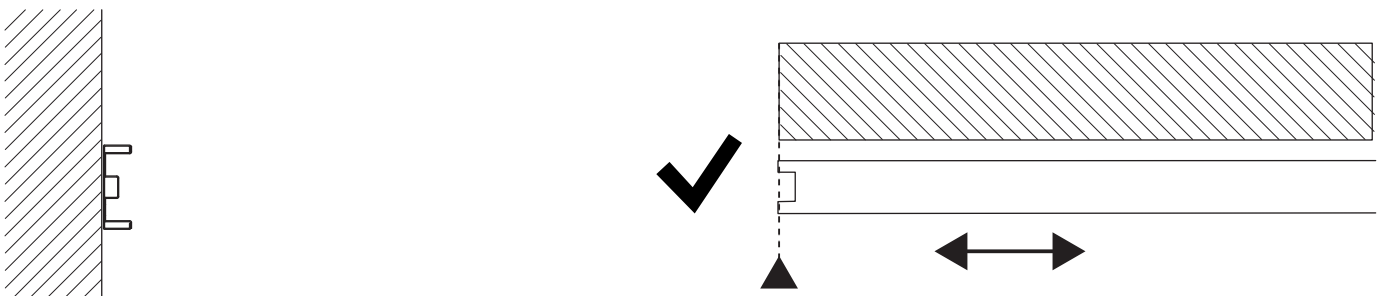
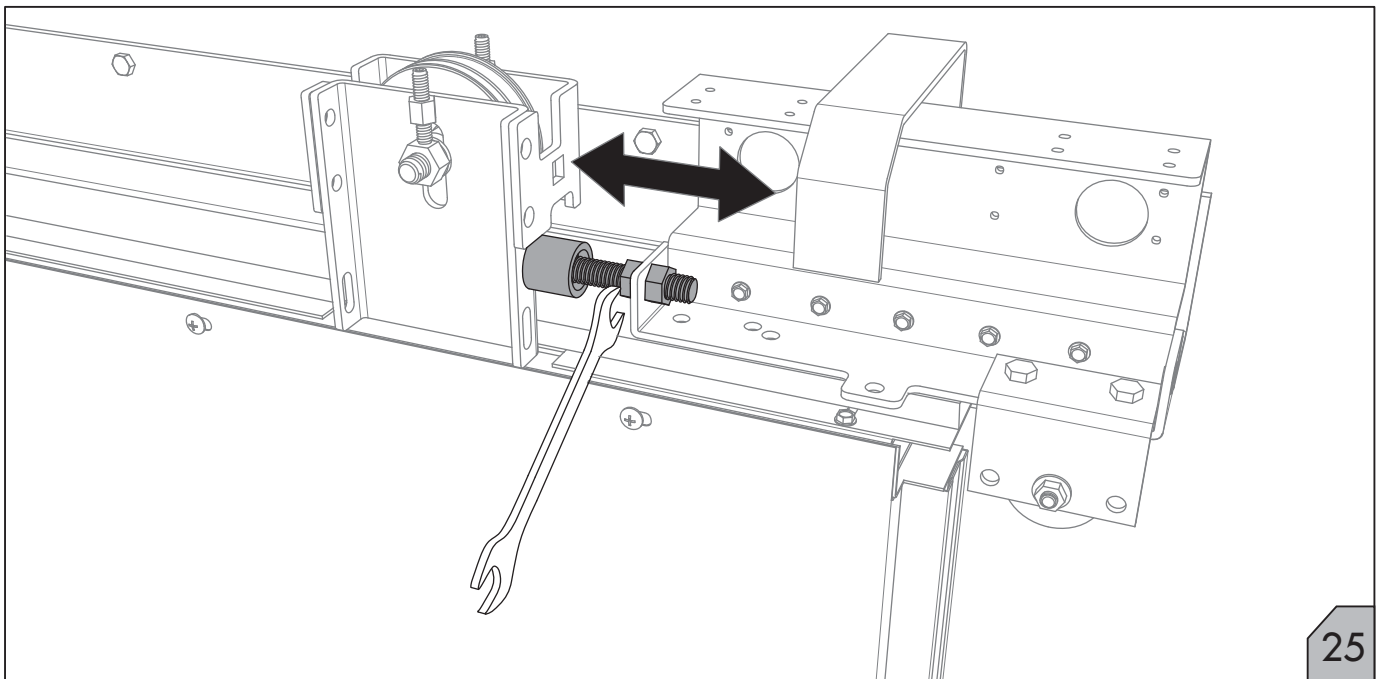
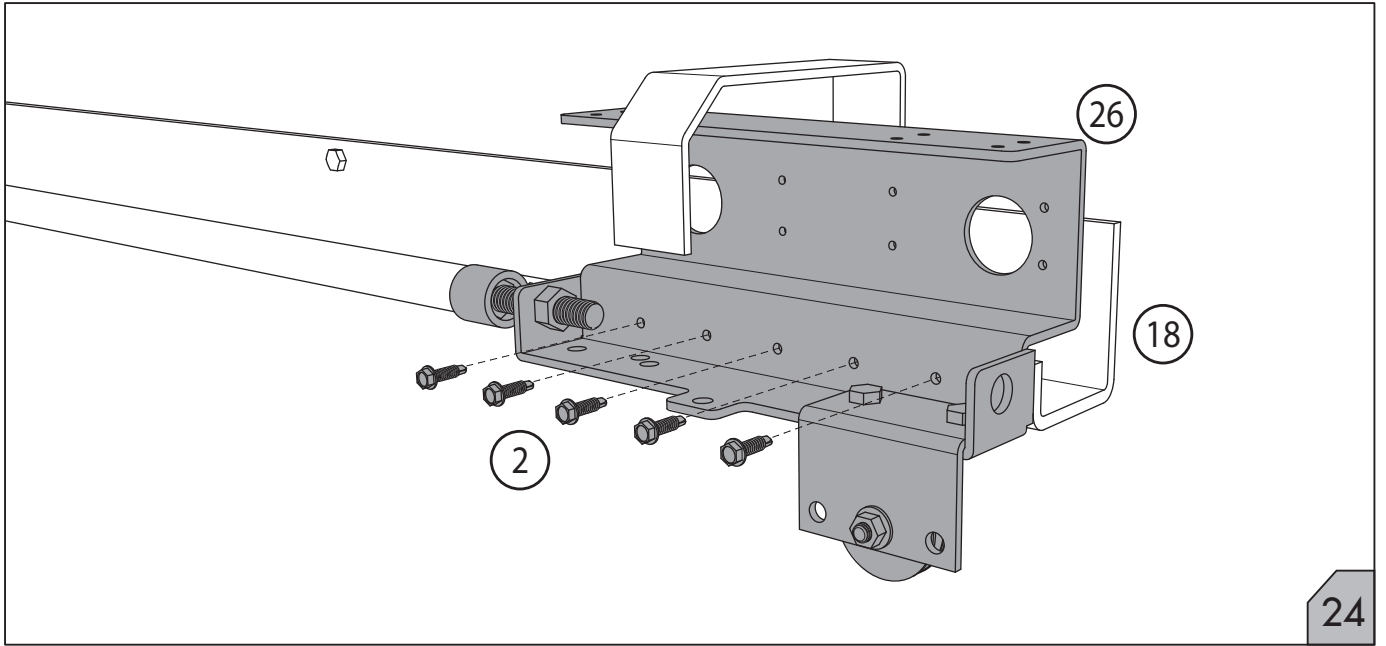
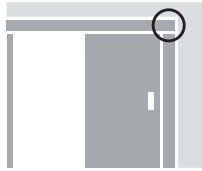

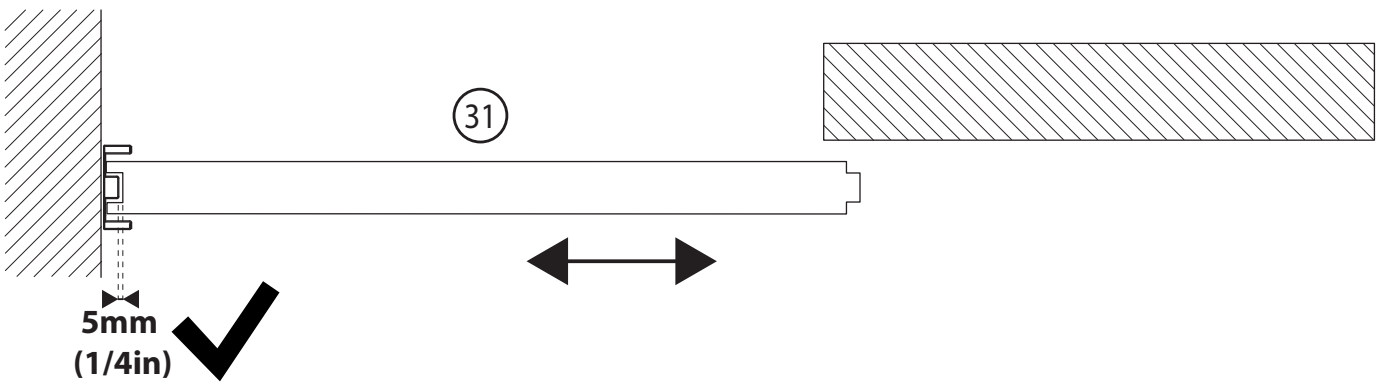
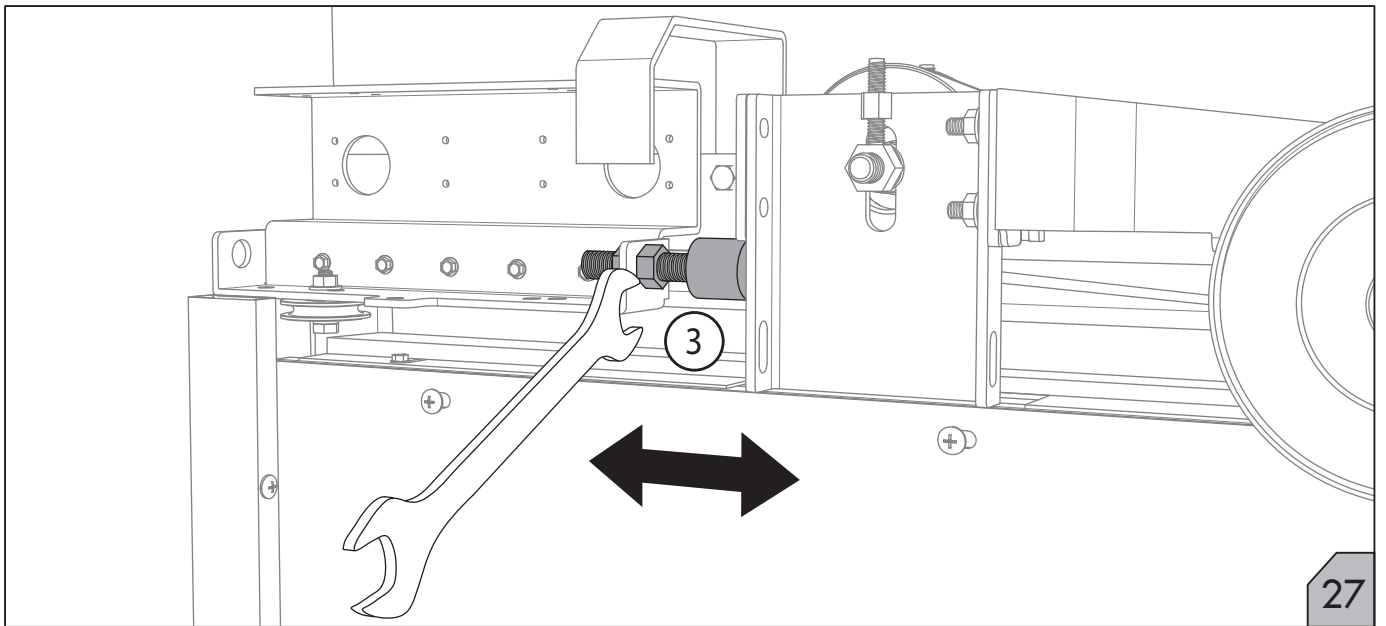
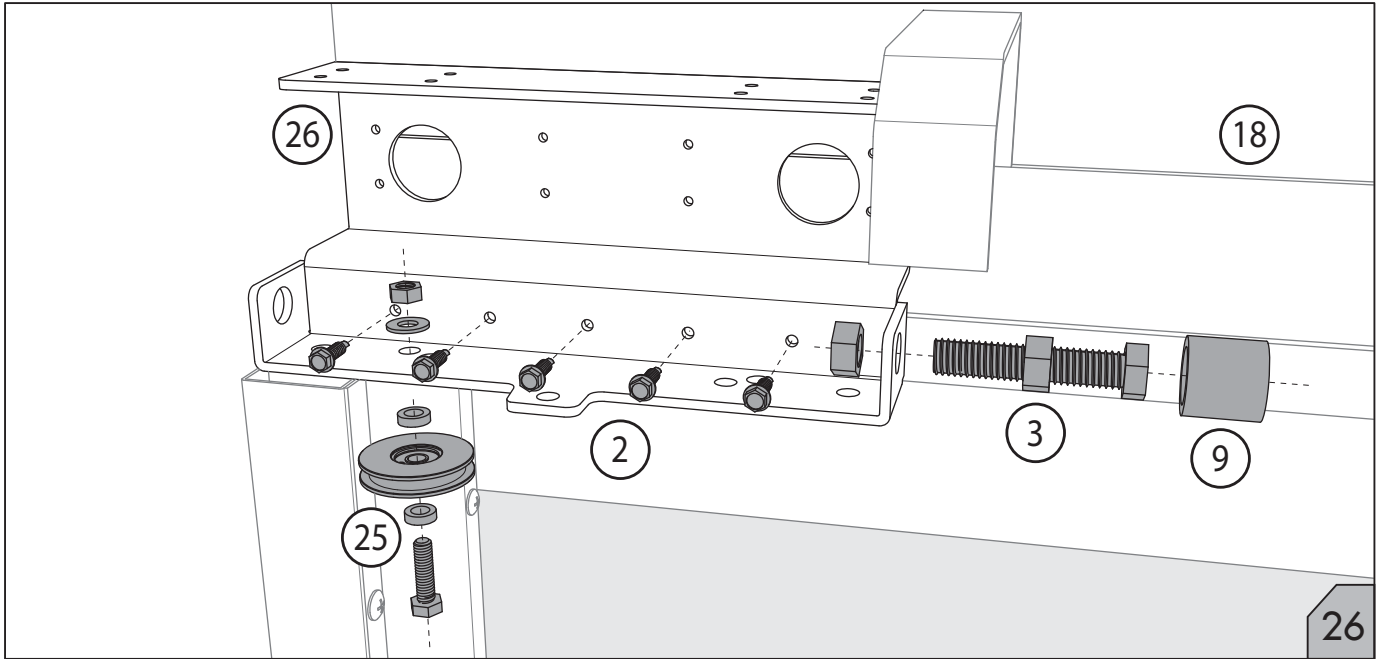
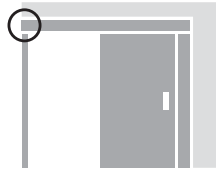

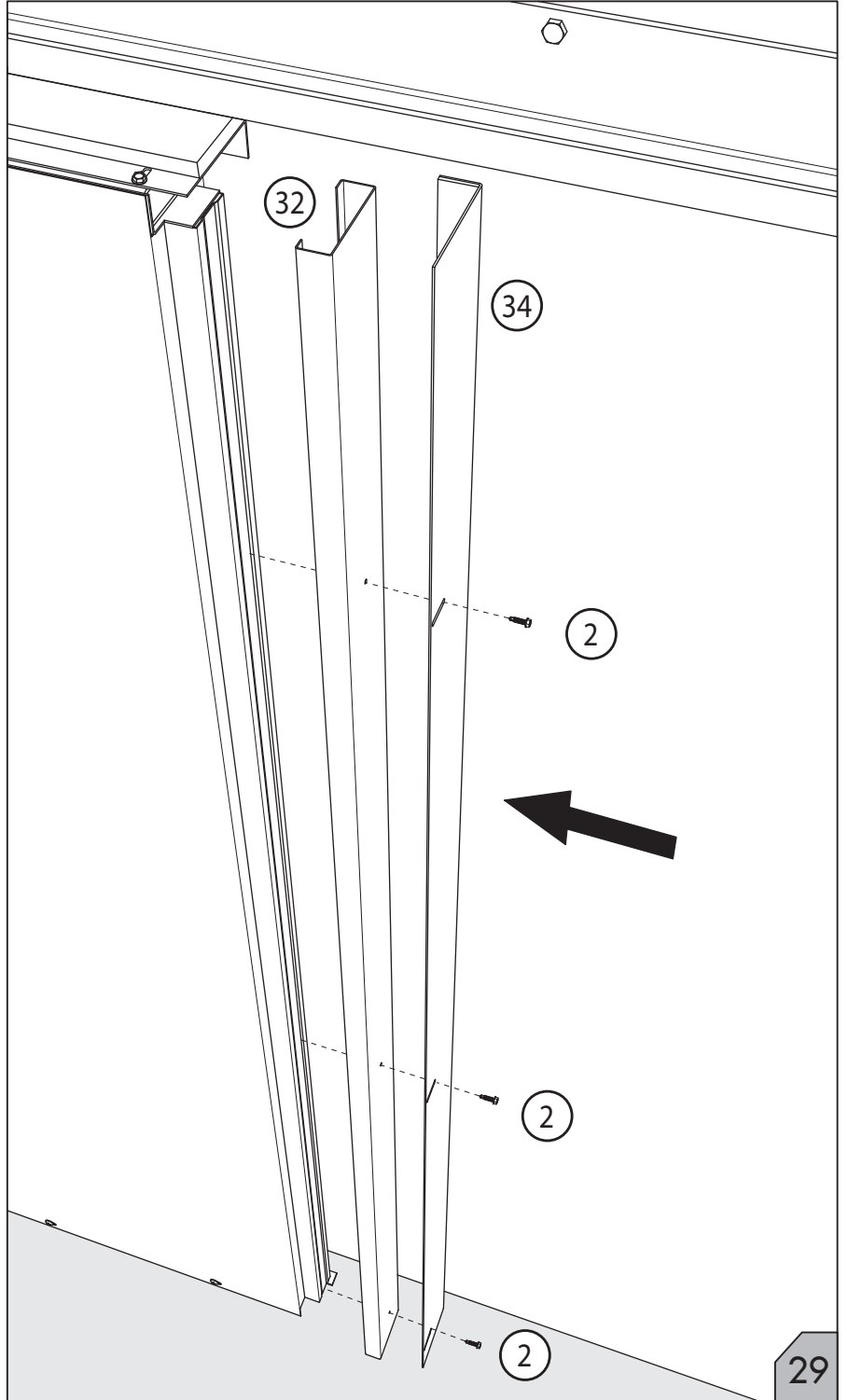
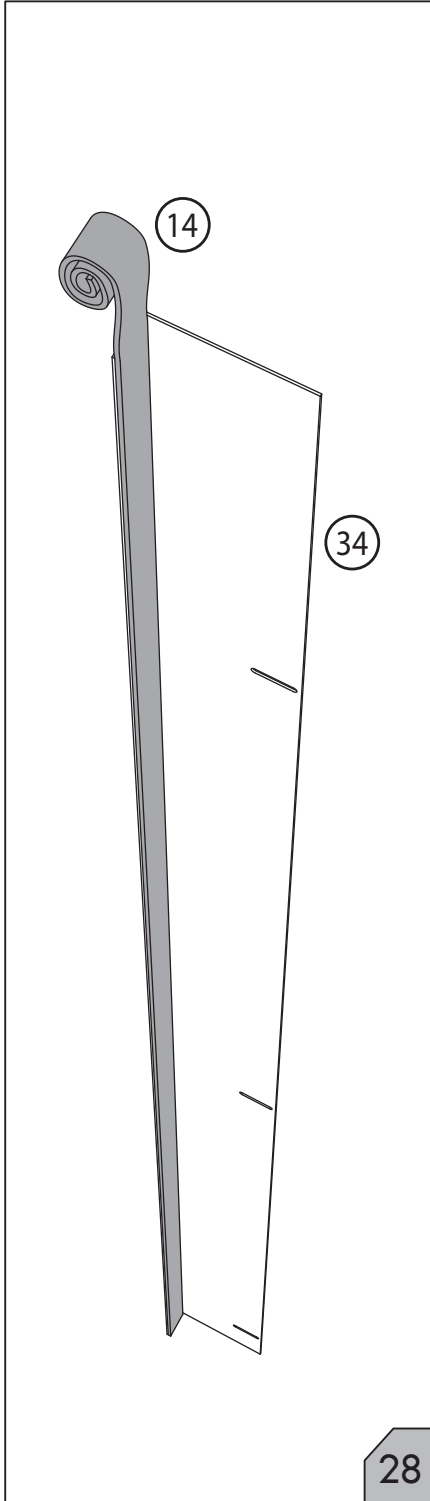
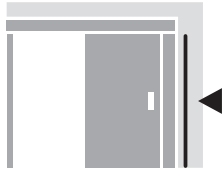

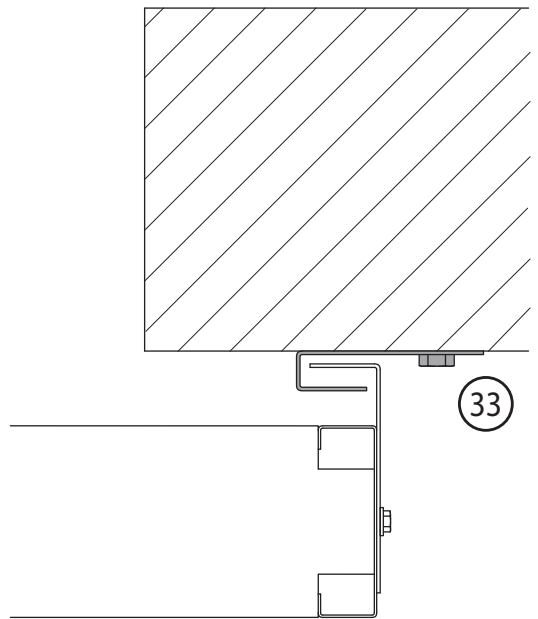
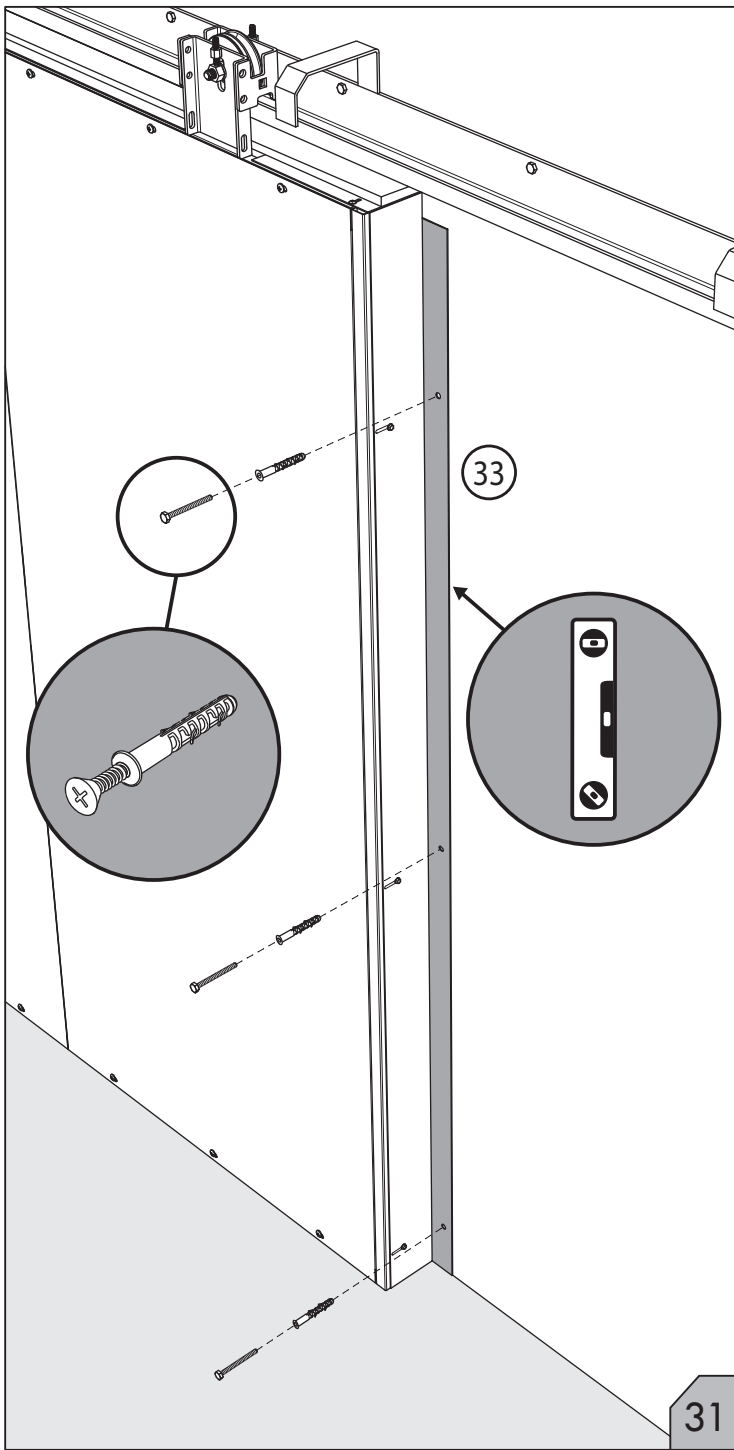
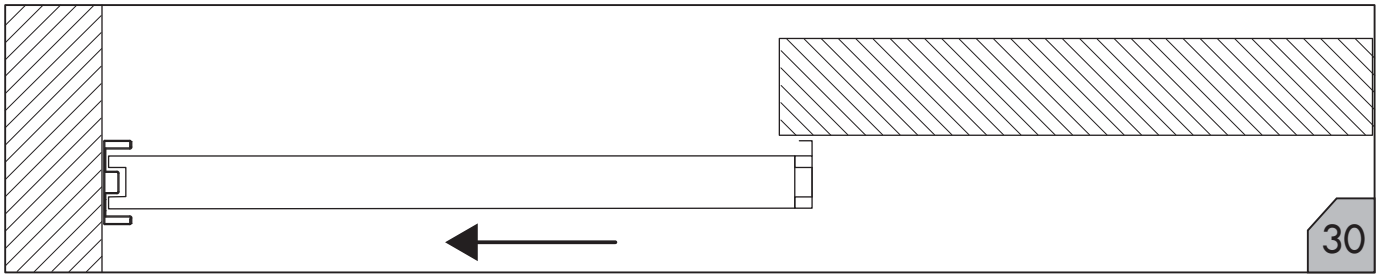
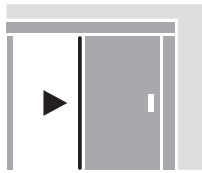

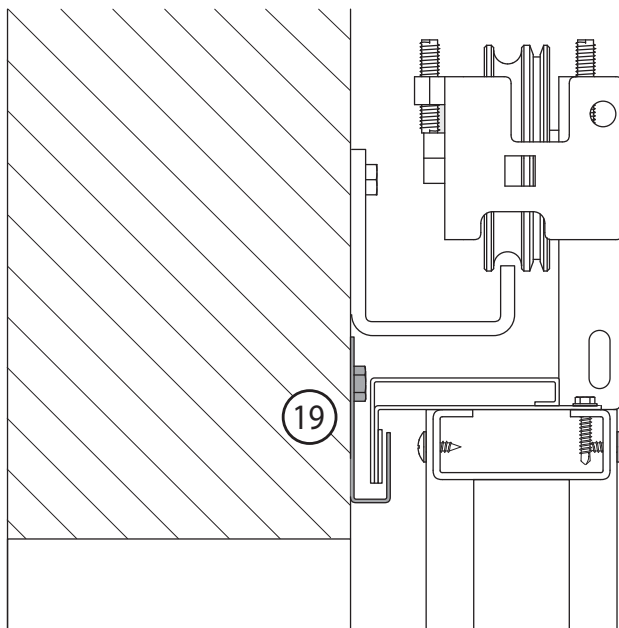
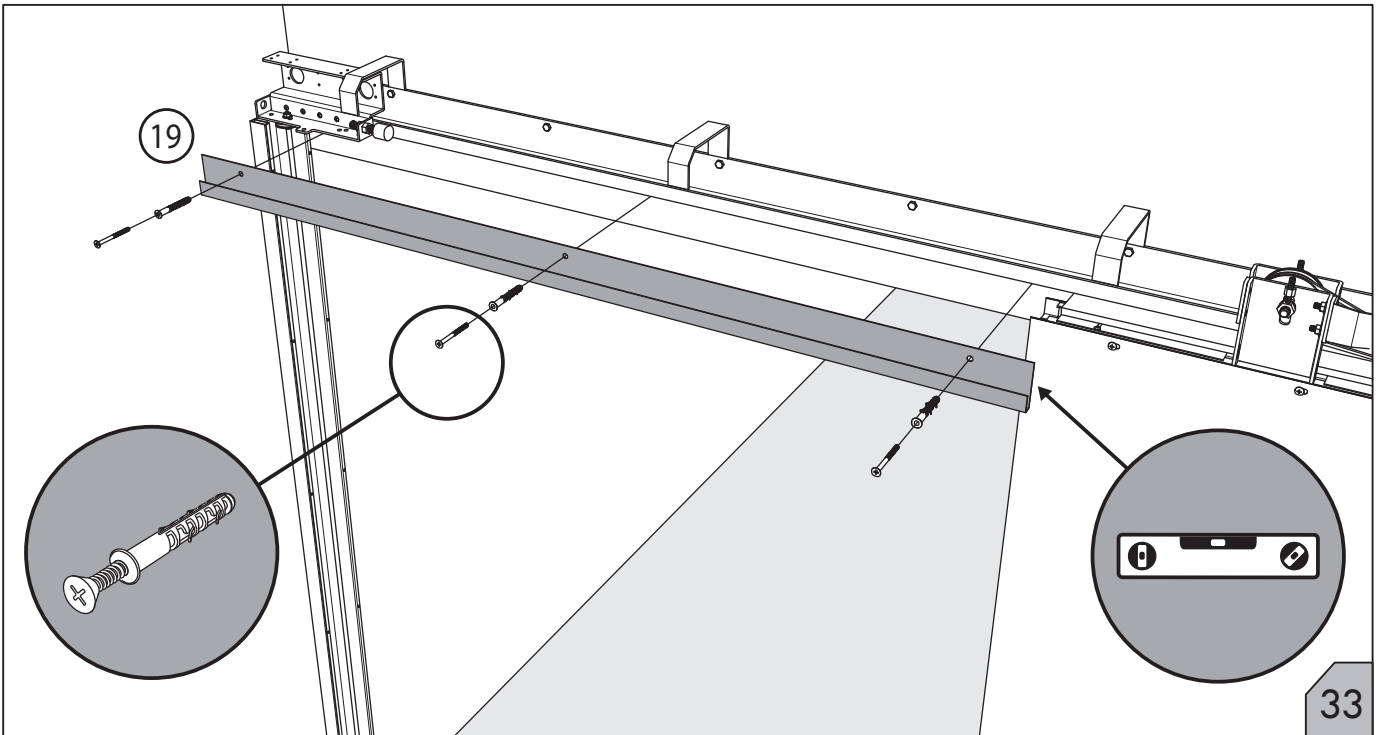
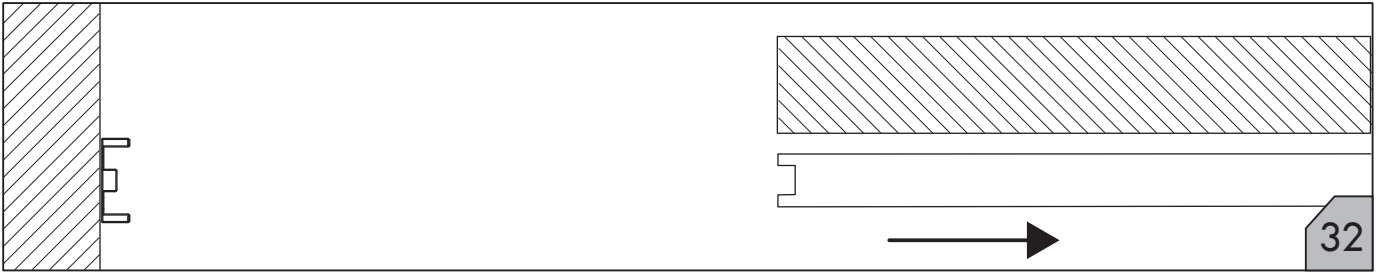
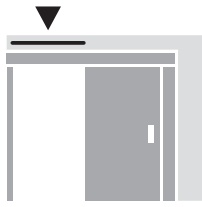

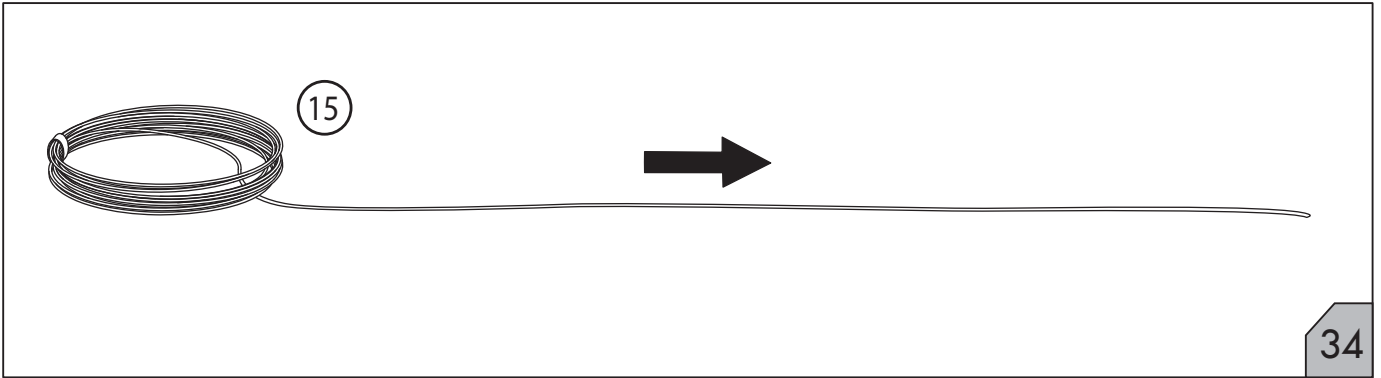
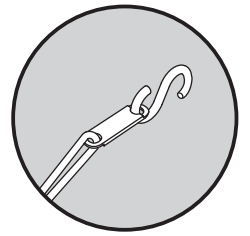
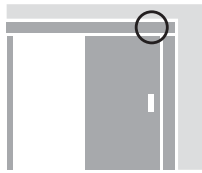

34

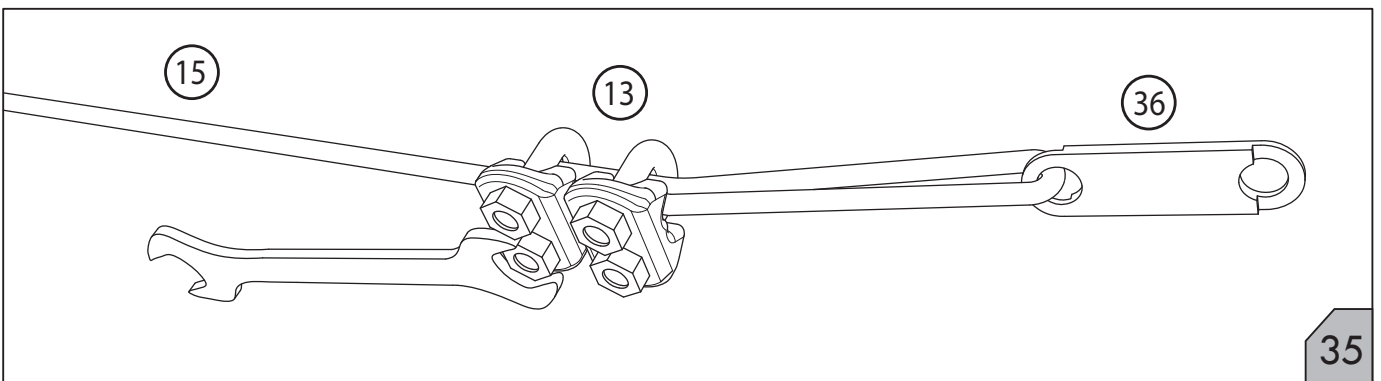

35

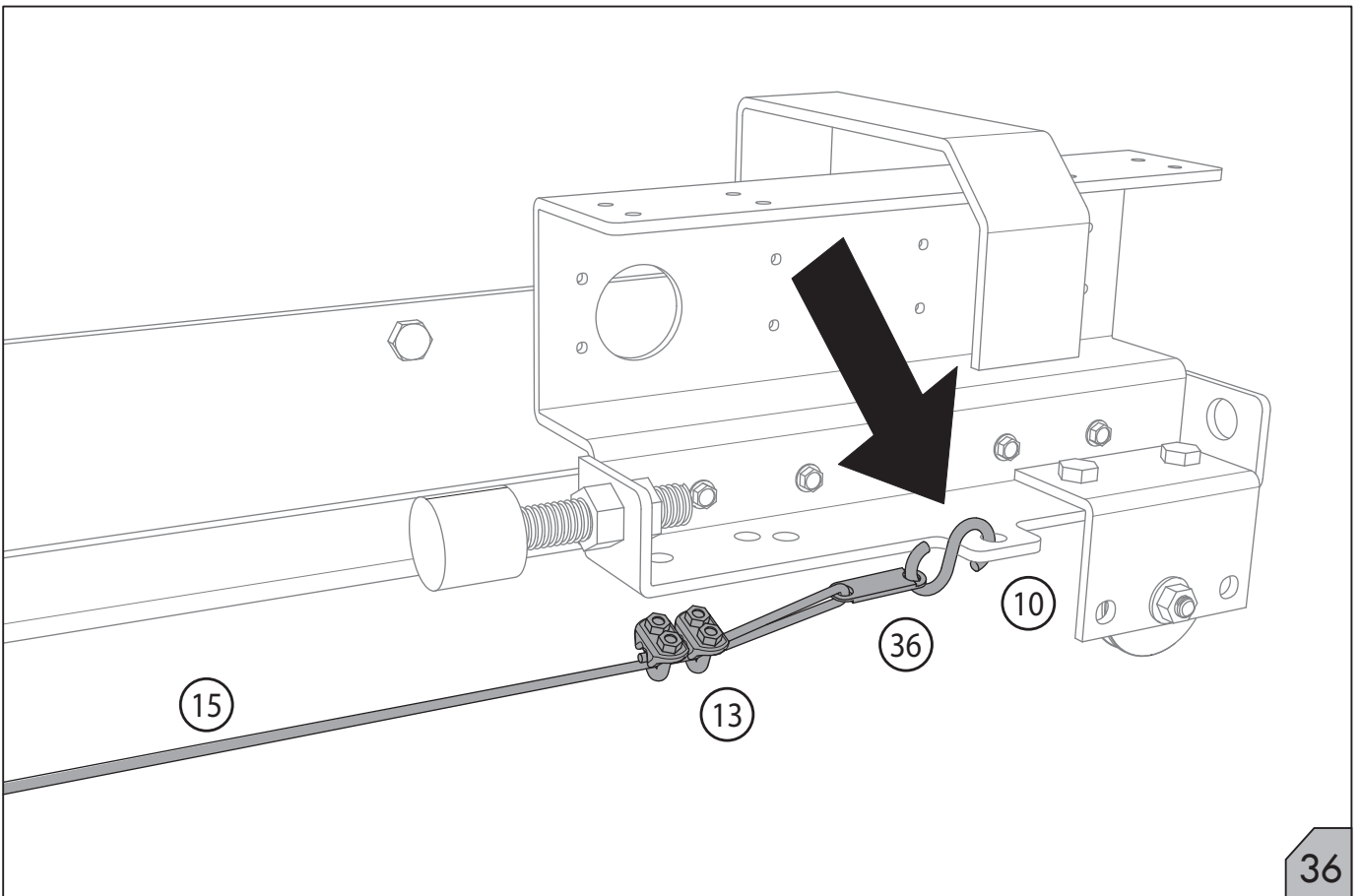

36

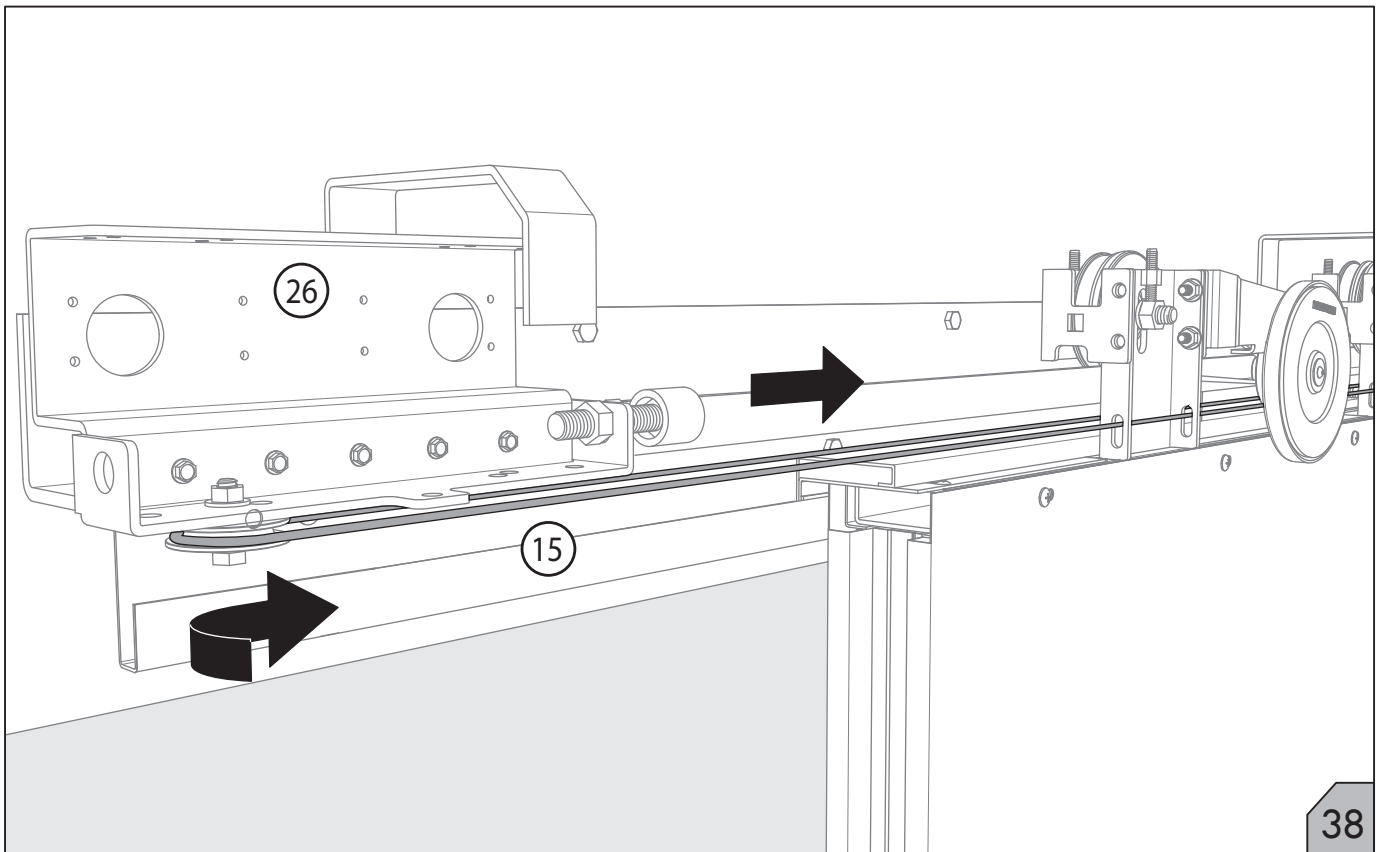
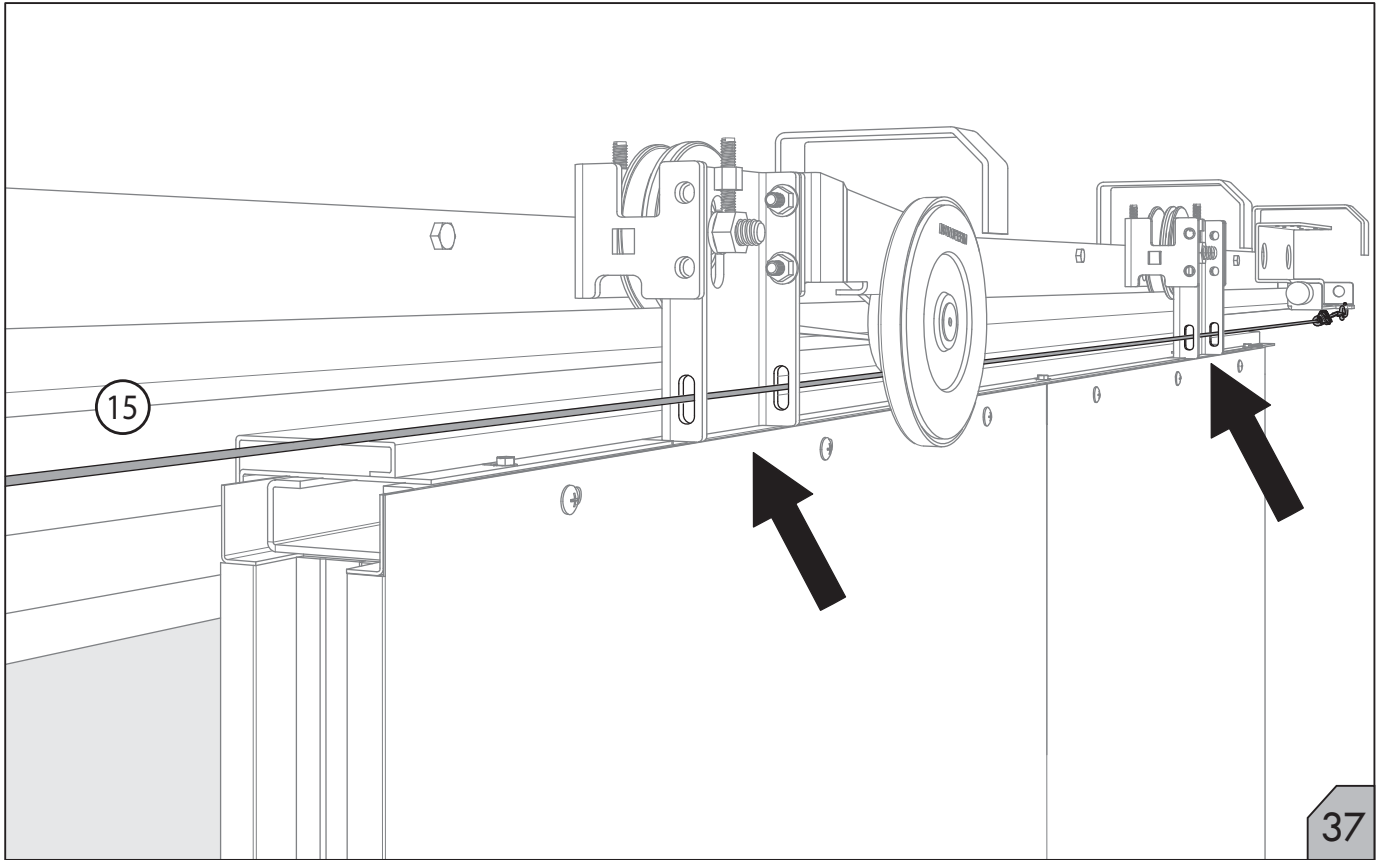
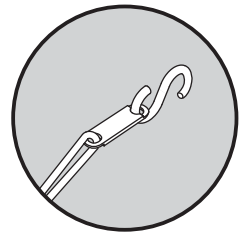
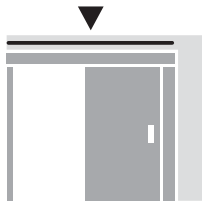

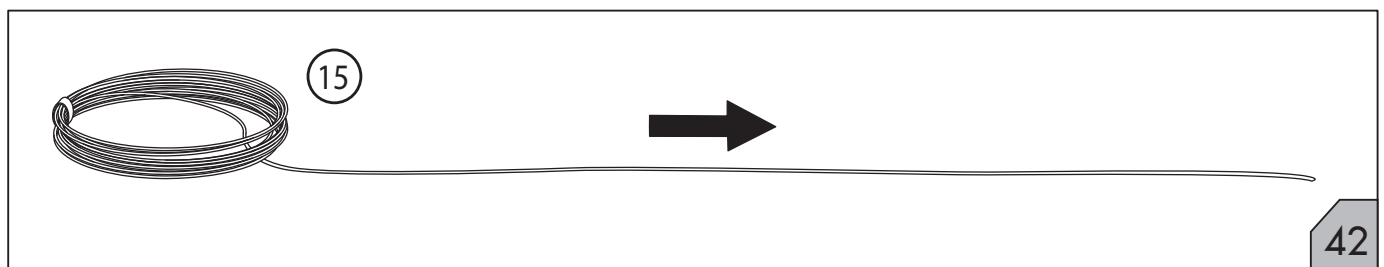
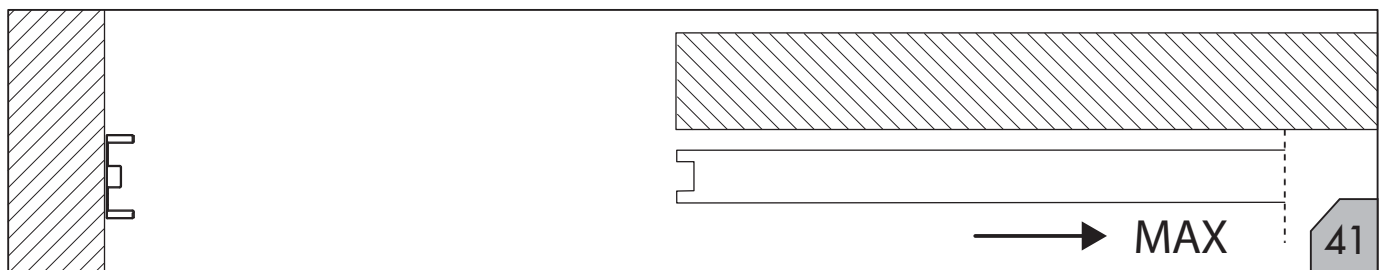
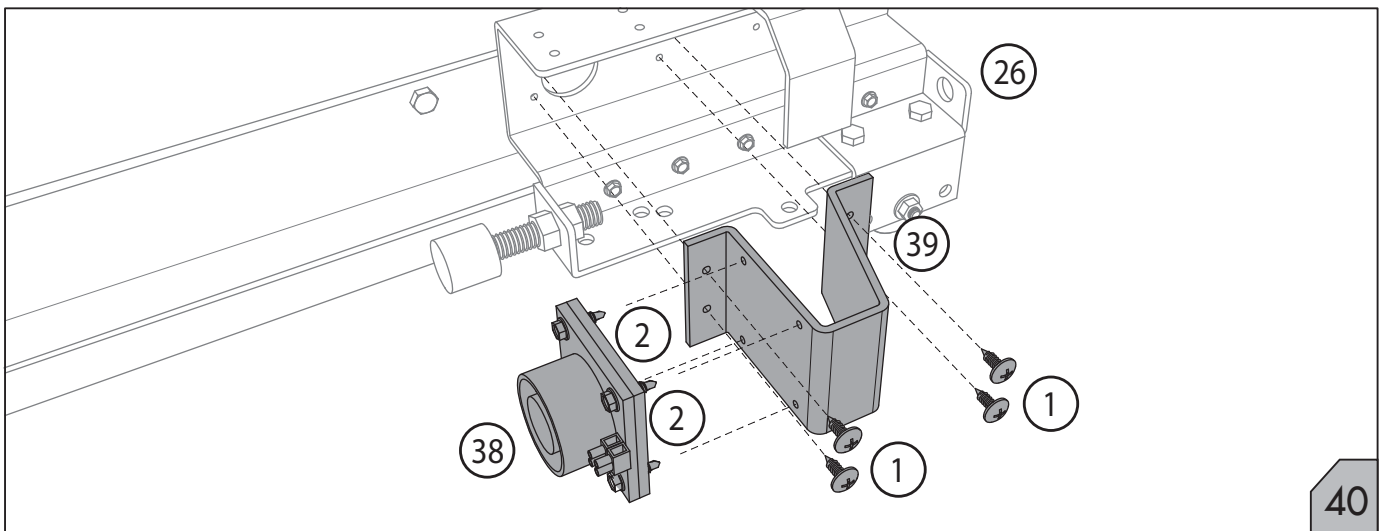
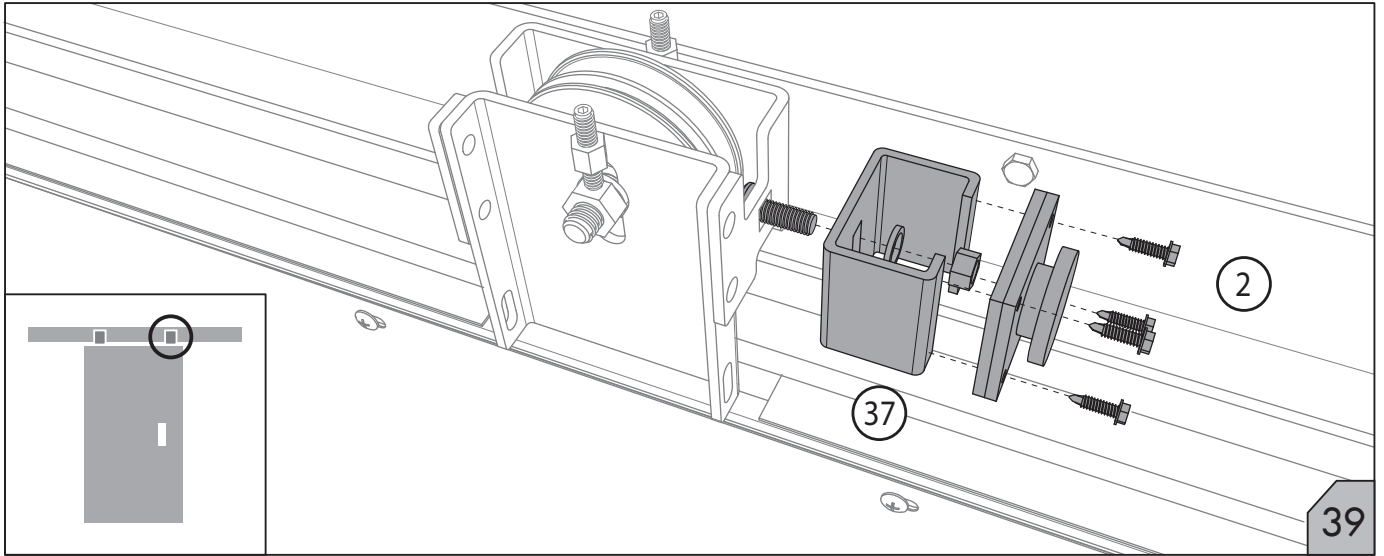
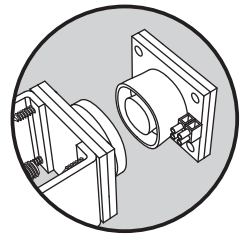
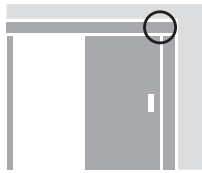

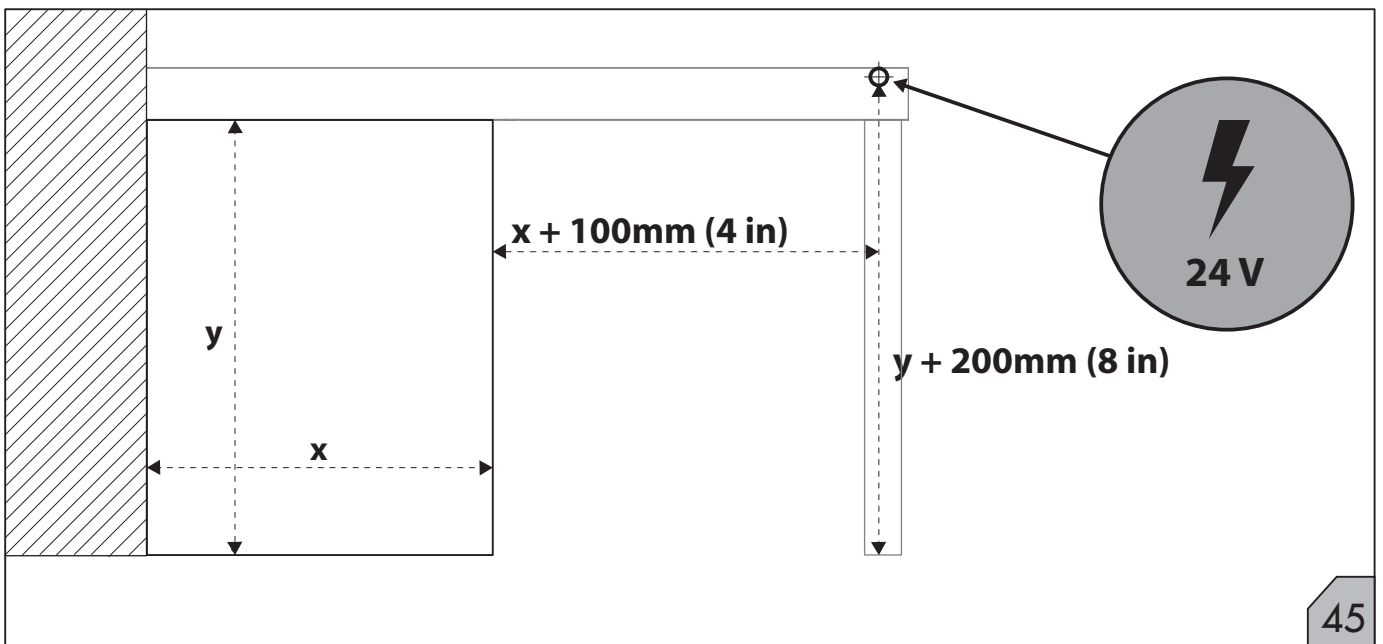
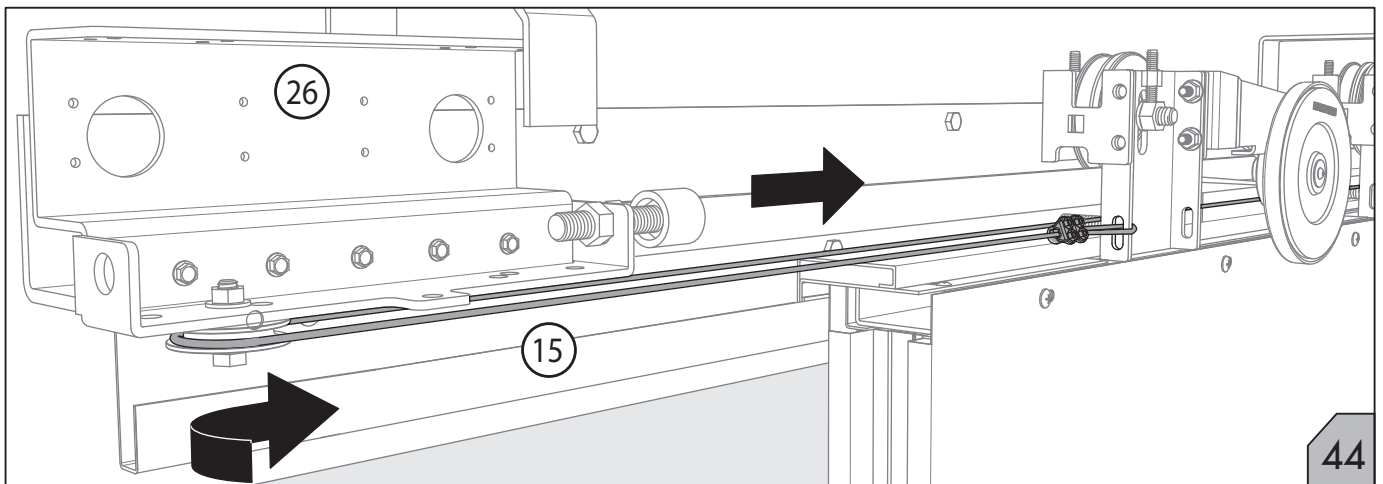
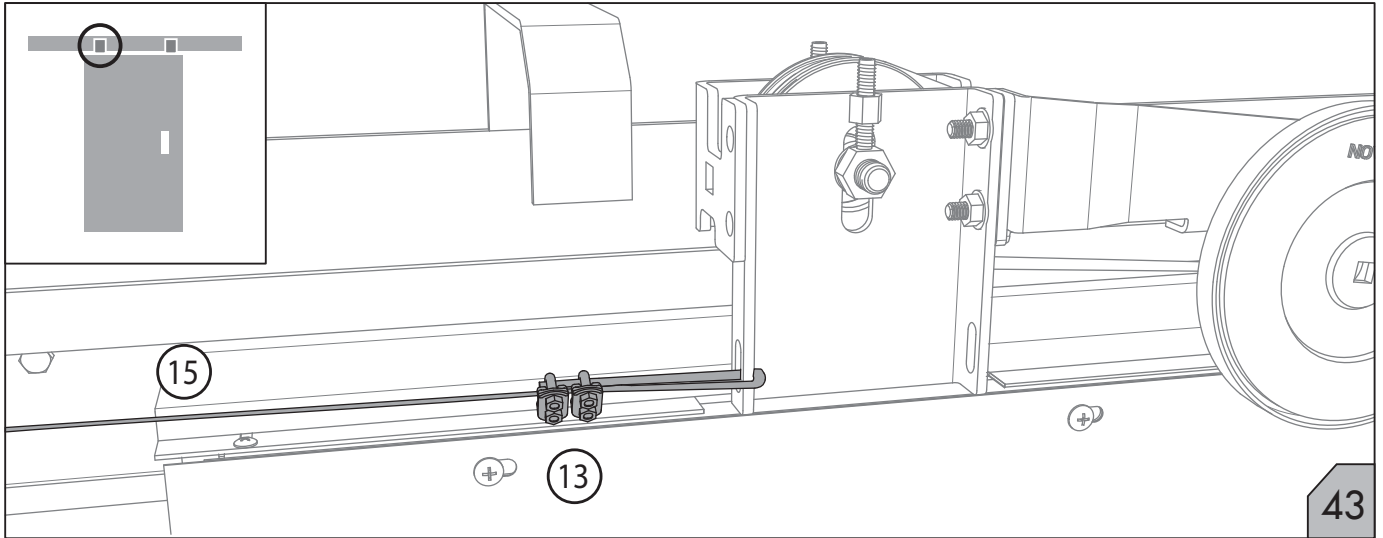
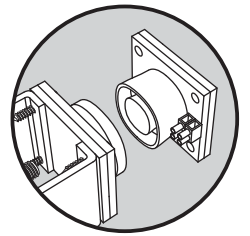
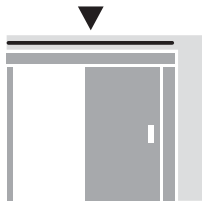

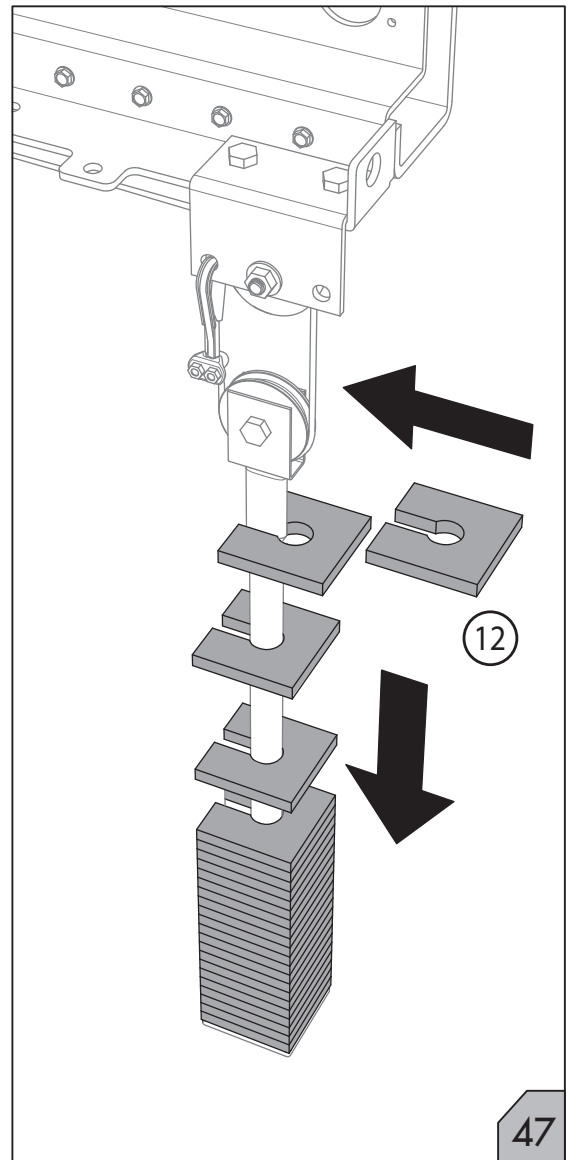
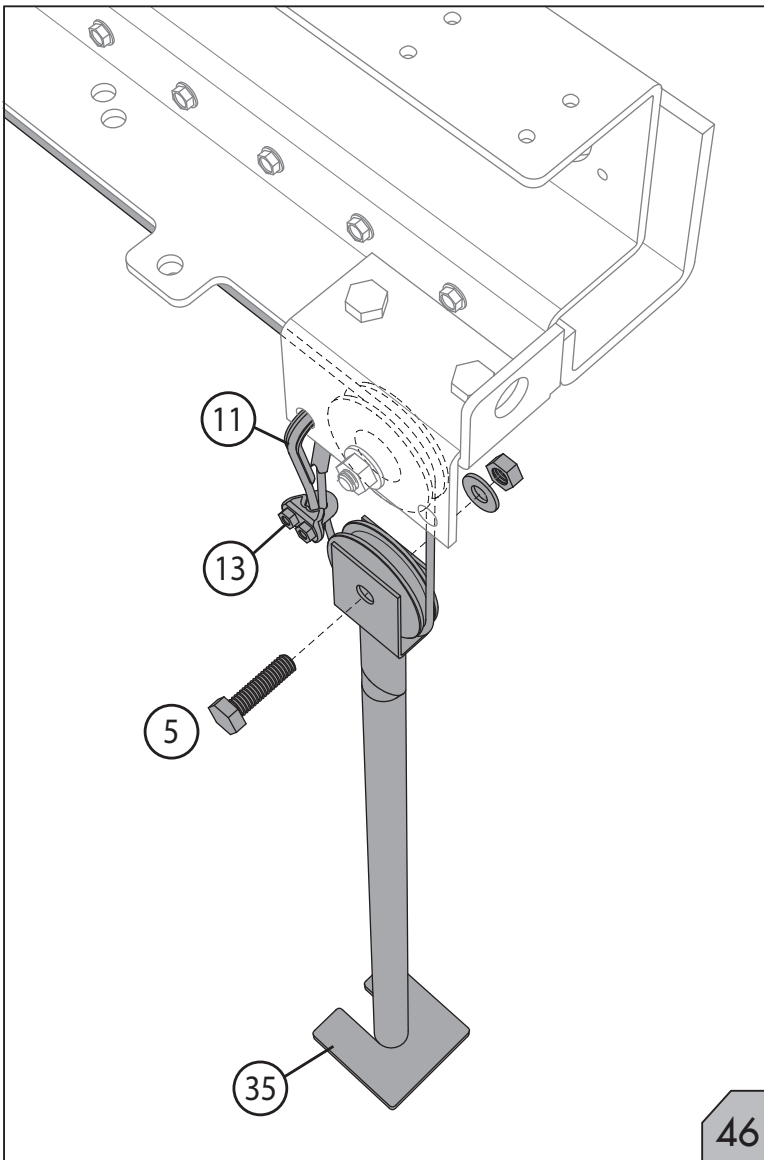
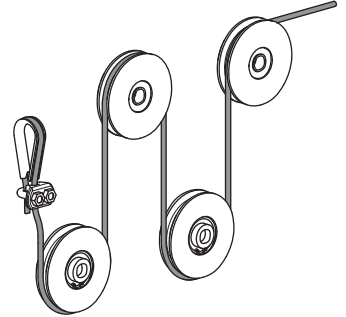
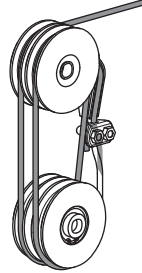
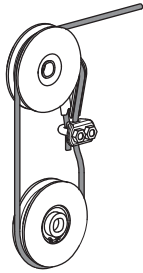
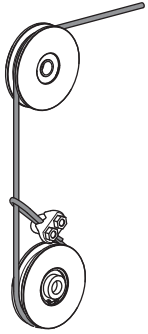
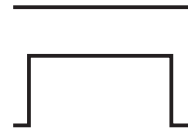
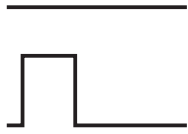
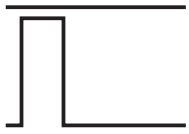
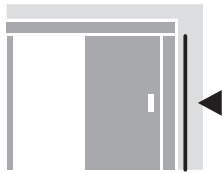

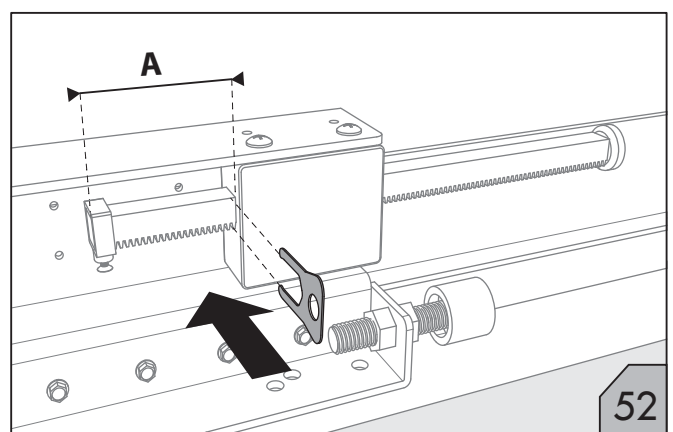
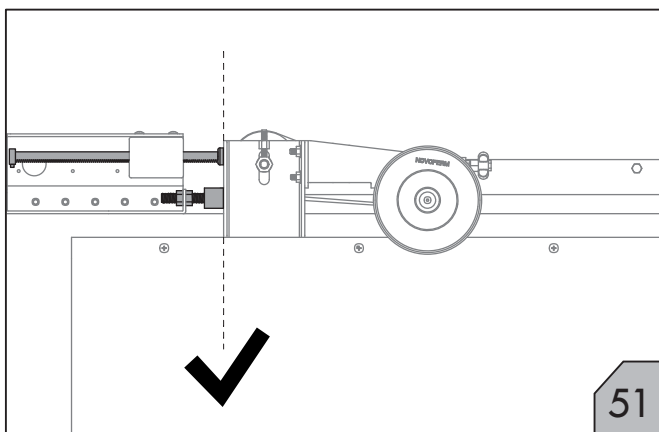
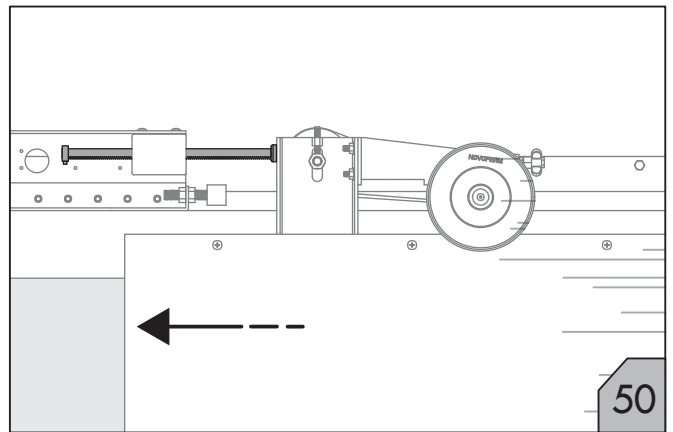
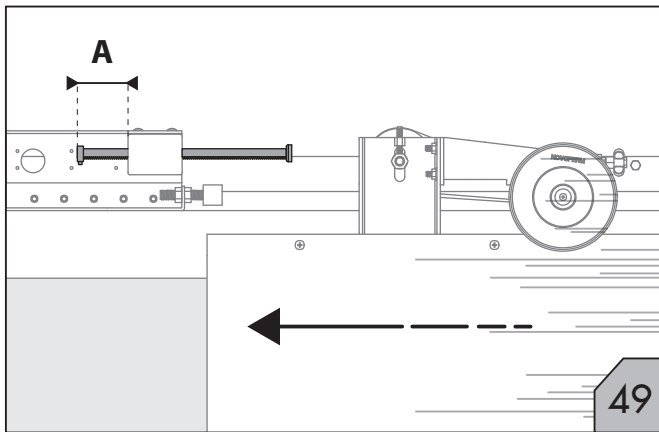
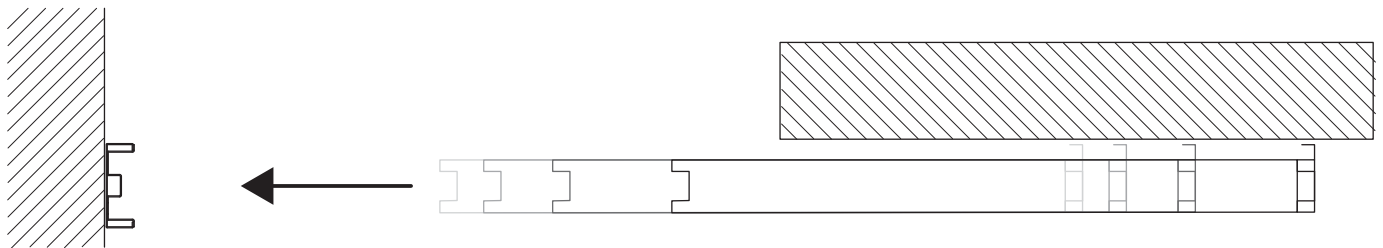
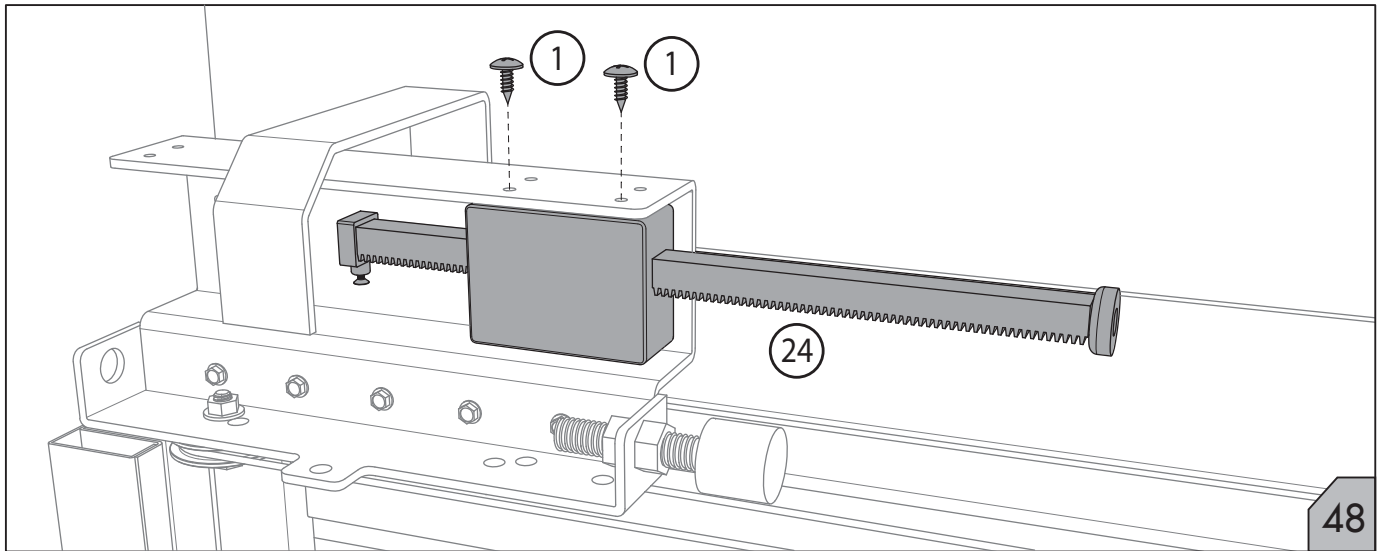
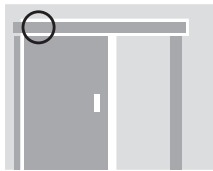

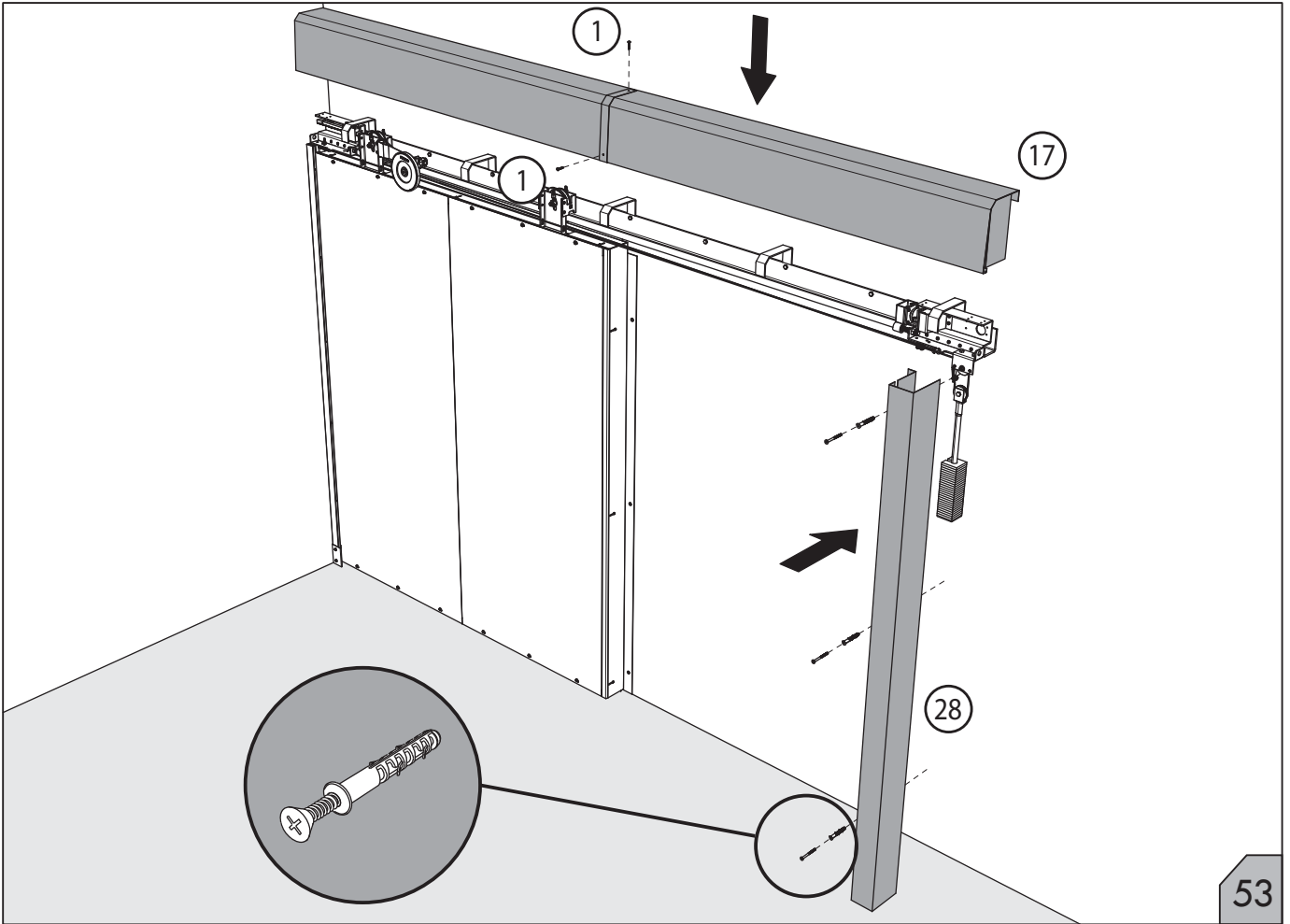
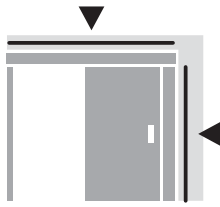

53

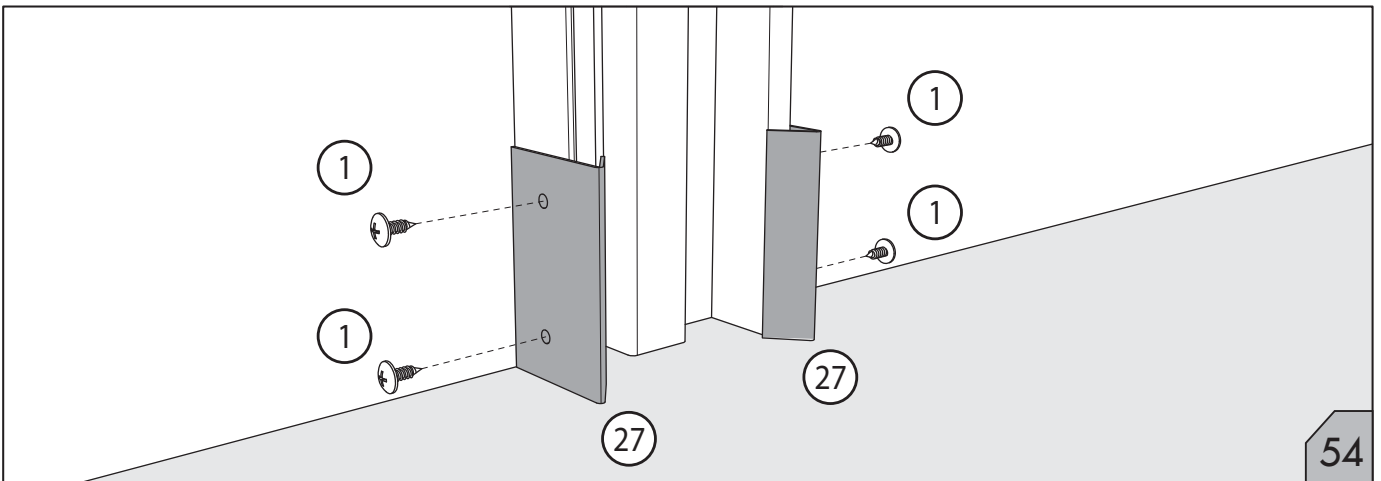
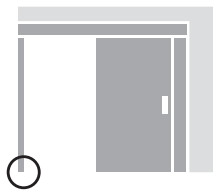

54

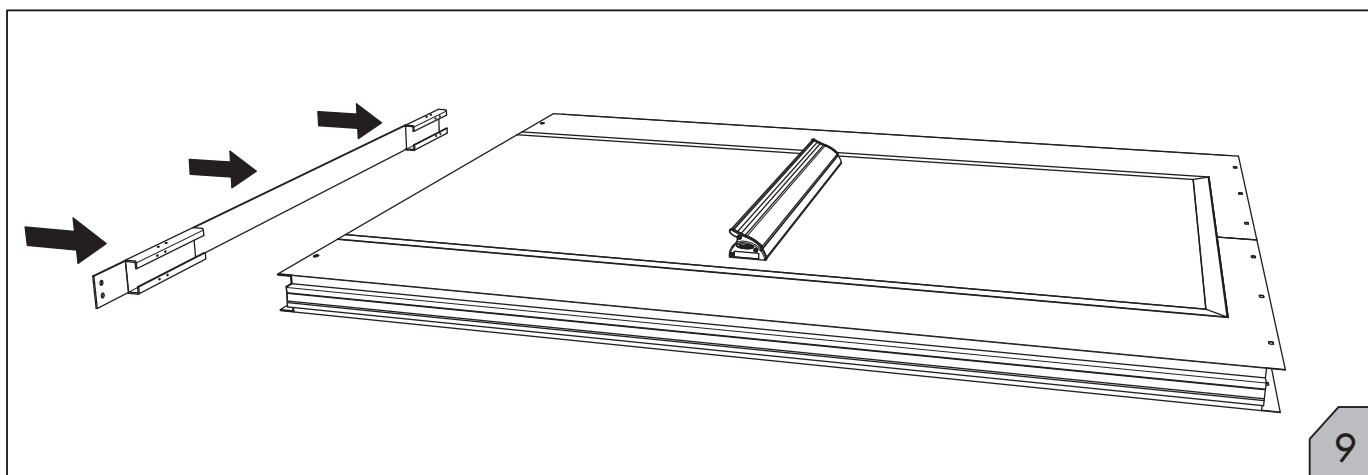
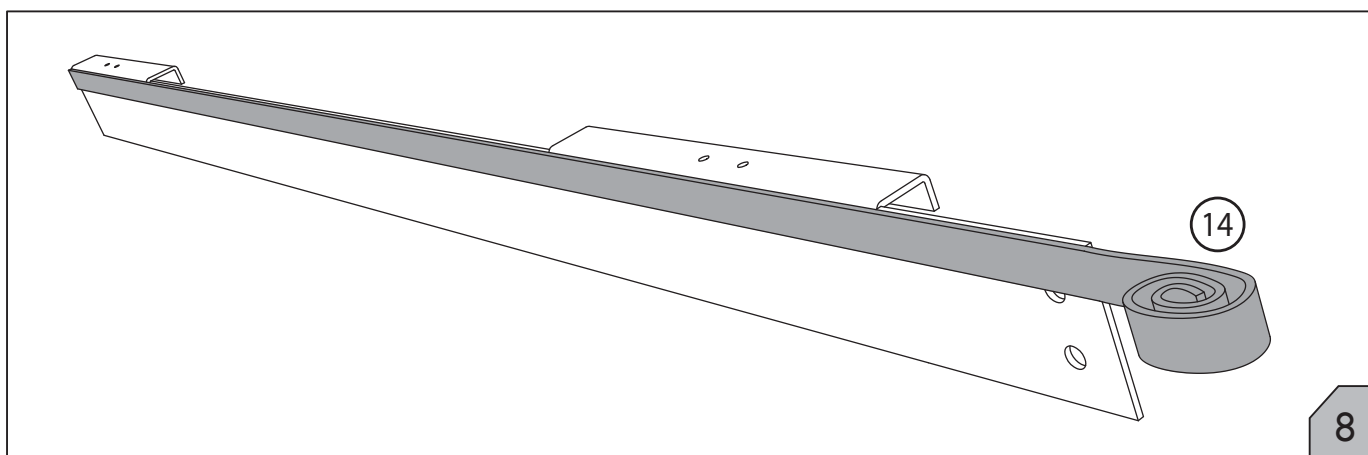
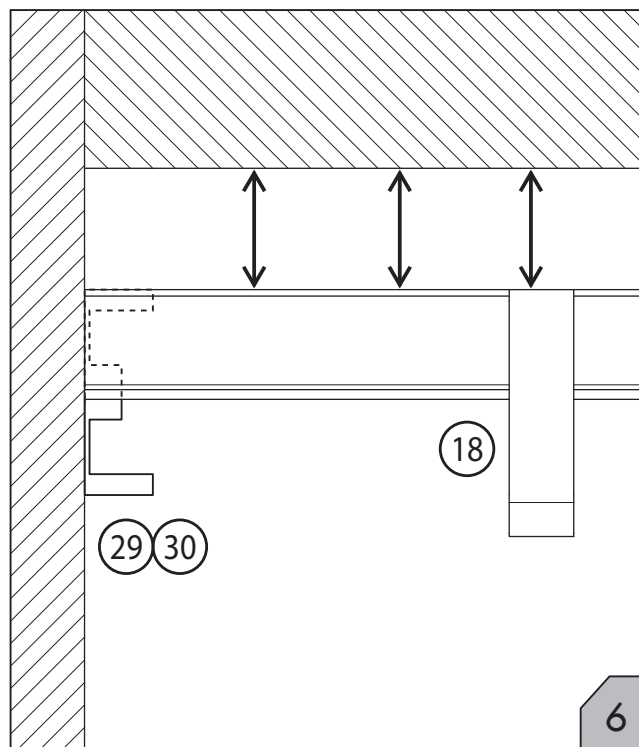
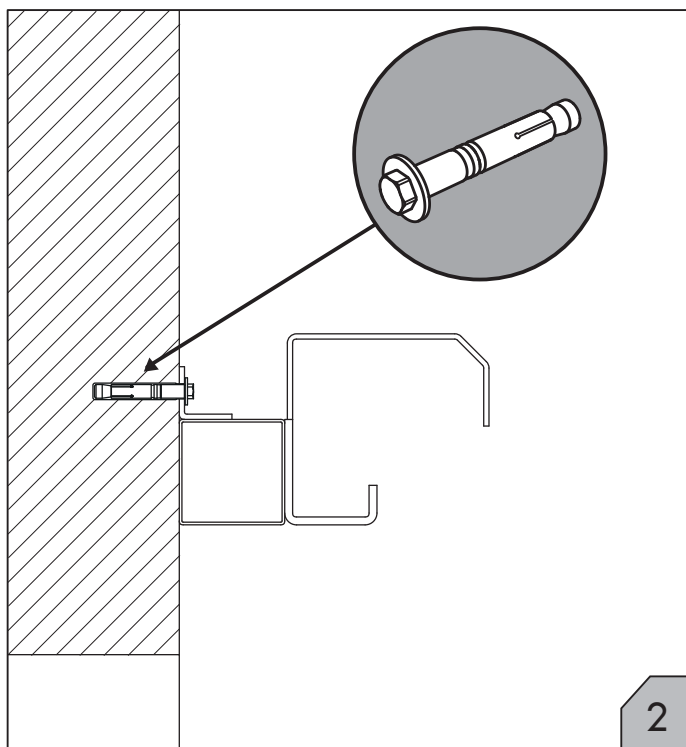
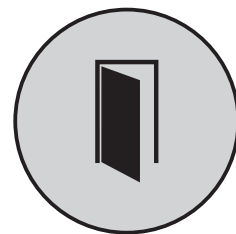

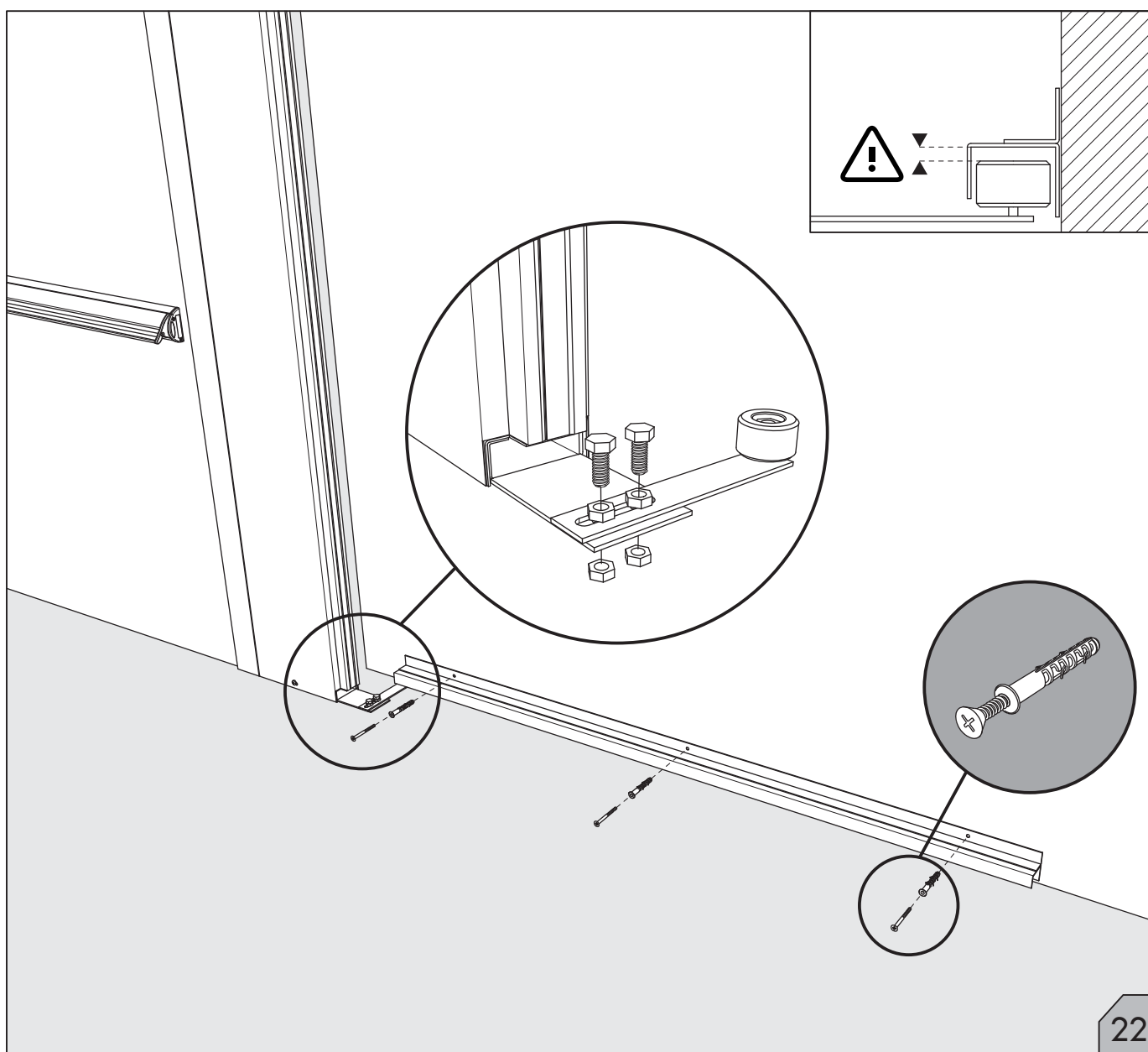
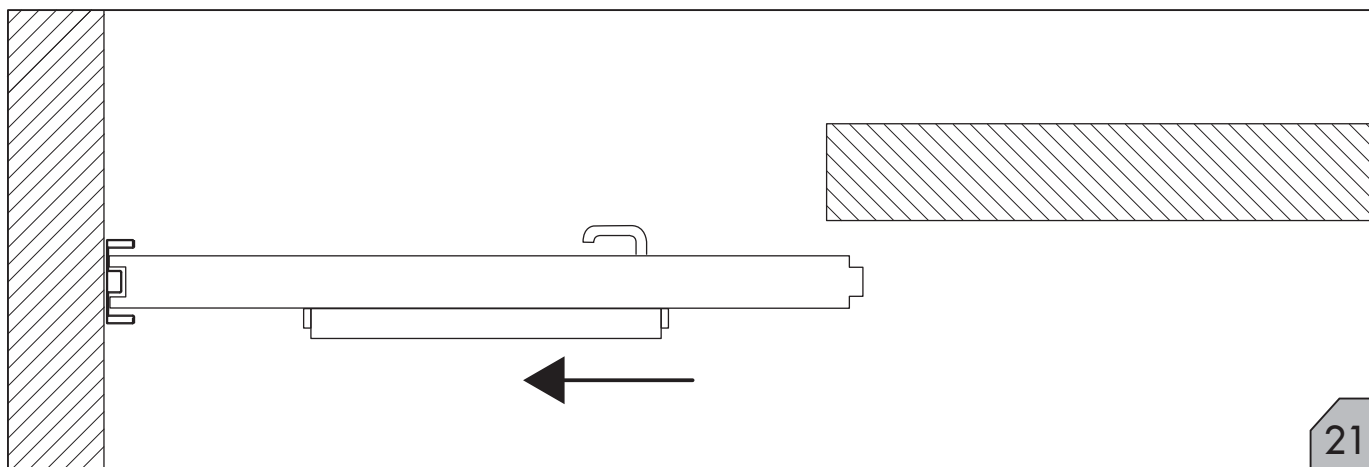
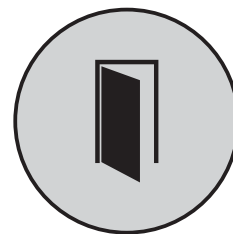

GENERAL INFORMATION

- In case of prolonged time in stock, the doors must be held in cool and dry place, to the shelter of the sun, with pallet and/or leaves without protective film.
- These doors are designed for purpose use. Any after mounting modification or fitting must be expressly approved by producer.
- Do not employ fixed unrelated elements to keep the door open. The keeping open of the mobile leaf is to be done only by means of devices installed or accepted from the manufacturer.
- Except specific agreement while ordering, sliding doors are designed for inner rooms.
- The cleaning of the surface should be done with cleansers of normal domestic use, avoiding abrasive substances, or aggressive substances or solvents.
- Normally, doors are coated with epoxy polyester powder polymerized at 180° C. Prior of any further paint, we suggest a deep cleaning of surface with light sand-paper and then laying of a primer. In any case should be avoided nitro varnishes.

AVVERTENZE GENERALI D'USO

- *In caso di stoccaggio prolungato, le porte vanno tenute in luogo fresco e asciutto, al riparo dal sole, con pallet e/o ante privati dell'eventuale pellicola protettiva.*
- *L'utilizzo di questi serramenti non può prescindere dalla considerazione che si tratta di chiusure tecniche con obiettivi funzionali. Ogni modifica o aggiunta deve essere preventivamente approvata dall'azienda.*
- *Non vanno impiegati elementi fissi per il mantenimento dell'apertura dell'anta. L'apertura dell'anta mobile può essere mantenuta solo con dispositivi di idoneità accertata dalla casa produttrice.*
- *Salvo precisi accordi in sede di ordinazione, le porte sono realizzate per essere collocate in luoghi chiusi.*
- *La pulizia delle superfici va eseguita con detersivi di normale uso domestico, evitando accuratamente l'uso di abrasivi, di sostanze aggressive o solventi.*
- *Le porte di serie sono finite con polveri epossidico-poliesteri termoindurenti a circa 180°. Per l'applicazione di qualsiasi smalto si consiglia l'applicazione di un primer epossidico bicomponente, previa carteggiatura e spolveratura della superficie. In ogni caso si sconsiglia l'applicazione di vernici al nitro.*

OPERATION	DESCRIPTION AND NOTES	INTERVENTO	DESCRIZIONE
Grease and regulate the wheels	Verify that the leaf maintains an height between 5 and 15 mm from floor. On the contrary, make the regulation as per present manual instructions.	<i>Ingrassaggio e registrazione ruote</i>	<i>Preliminarmente si deve verificare che l'anta rispetto al pavimento si trovi ad una altezza compresa fra 5 e 15 mm.</i>
Check leaf space, check leaf	The leaf and the labyrinths must have no deformation, no corrosion, no perforations.	<i>Controllo giochi e verifica integrità anta</i>	<i>L'anta e i labirinti devono essere privi di deformazioni, privi di fenomeni di corrosione, privi di forature.</i>
Regulate the self-closing mechanism	In case of high speed while closing, check if dampers are working properly and, in case, adjust them (see mounting instructions).	<i>Regolazione dispositivi di autochiusura</i>	<i>In caso di eccessiva velocità di richiusura verificare che i dispositivi di regolazione siano integri ed eventualmente provvedere alla loro registrazione.</i>
Substitute damaged components	The accessories for fire proof doors must be supplied by specialised dealers. No responsibility in case of improper uses.	<i>Sostituzione parti usurate, danneggiate o manomesse</i>	<i>Gli accessori per porte tagliafuoco devono essere reperiti da rivenditori autorizzati.</i>

MAINTENANCE TIMING RECOMMENDED

MANUTENZIONE TIMING

DESCRIPTION	DESCRIZIONE INTERVENTO	PERIOD <i>PERIODICITÀ</i>		
		Light usage <i>Uso leggero</i>	Medium usage <i>Uso medio</i>	Intensive usage <i>Uso intensivo</i>
Check self-closing mechanism.	Verifica funzionamento autochiusura.	Each month <i>Ogni mese</i>	Each month <i>Ogni mese</i>	Each month <i>Ogni mese</i>
Check self closing system. Check slide mechanism and bad sliding. Regulation of shock absorbers.	Controllo dispositivo di autochiusura. Controllo organi di scorrimento e verifica giochi. Regolazione ammortizzatori.	Every six months <i>Ogni sei mesi</i>	Every three months <i>Ogni tre mesi</i>	Every month <i>Ogni mese</i>
Verify fixing bolts.	Verifica serraggio bulloneria.	Every year <i>Ogni anno</i>	Every six months <i>Ogni sei mesi</i>	Every three months <i>Ogni tre mesi</i>
Check electric operator (transmission cable or strap tension and setting tension spring, lubricating level, verify surface, adherence of the electromagnetic brake).	Controllo motorizzazione (tensione cavo o cinghia di trasmissione e taratura molla tenditrice, livello lubrificante, verifica stato superficie, aderenza del freno elettromagnetico).	Every year <i>Ogni anno</i>	Every six months <i>Ogni sei mesi</i>	Every three months <i>Ogni tre mesi</i>
Verify the pads. Verify possible lock worn-out. Check gaskets.	Verifica stato cuscinetti. Verifica eventuale logorio serratura. Controllo stato guarnizioni.	Every four years <i>Ogni quattro anni</i>	Every two years <i>Ogni due anni</i>	Every year <i>Ogni anno</i>
Substitute worn parts. Substitute damaged or tampered components.	Sostituzione parti usurate. Sostituzione parti danneggiate o manomesse.	When necessary <i>Quando serve</i>	When necessary <i>Quando serve</i>	When necessary <i>Quando serve</i>

As indicative parameters, you could consider the following scheme to classify the level usage of the door.

Light usage = 1 – 3 daily openings
Medium usage = 2 – 5 daily openings
Intensive usage = 4 – 10 daily openings

The above parameters refer to a doors with size approx. 16 mq; in case of different size increase or diminish the cycles of opening/closing; For size over 25 mq the intensive daily usage is not proper. The maintenance program must be personalised in case of particular conditions (such us public parking, etc.). In case of sliding doors normally not operating, we suggest at least a monthly checking of the self-closing system.

A titolo orientativo si possono assumere i seguenti parametri di utilizzo per identificare il tipo di uso a cui viene sottoposta la porta.

*Uso leggero = 1 - 3 aperture al giorno
Uso medio = 2 - 5 aperture al giorno
Uso pesante = 4 - 10 aperture al giorno*

I parametri sopra indicati sono calcolati su porte di superficie approssimativa 16 mq; per superfici diverse è opportuno aumentare o diminuire i cicli di utilizzo; per superfici oltre i 25 mq è sconsigliato l'uso intensivo. Per collocazioni particolari (ad es. porte motorizzate in parcheggi pubblici), il programma di manutenzione deve essere personalizzato. In ipotesi di portoni normalmente fermi è consigliata una verifica almeno mensile dell'autochiusura.



NOVOFERM SCHIEVANO s.r.l.
35012, Camposampiero - Padova (Italy)
Via Alessandro Volta, 1
TEL 049 / 9315111 - FAX 049 / 9301877

novoferm@novoferm.it
www.novoferm.it

